



---

# **VISTA**

# **5140XM**

---

**COMMERCIAL FIRE AND  
BURGLARY ALARM SYSTEM**

**INSTALLATION  
INSTRUCTIONS**

**® ADEMCO**

# **CONGRATULATIONS!**

## **On Your Purchase Of The Ademco 5140XM**

The purpose of these Installation Instructions is to give you a complete overview of the system, and provide instructions for installing a basic system.

### **CONTACTING TECHNICAL SUPPORT**

**PLEASE,**

**Before you call Technical Support, be sure you:**

- **READ THE INSTRUCTIONS!**
- **Check all wiring connections.**
- **Determine that the power supply and/or backup battery are supplying proper voltages.**
- **Verify your programming information where applicable.**
- **Note the proper model number of this product, and the version level (if known) along with any documentation that came with the product.**
- **Note your ADEMCO customer number and/or company name.**

**Having this information handy will make it easier for us to serve you quickly and effectively.**

You may contact Technical Support via Toll Free Fax. Please include your return fax number. You will receive a reply within 24 hours. You may also contact Technical Support via modem to ATLIS-BBS, Tech Support's Electronic Bulletin Board System. Replies are posted within 24 hours.

*East Coast Technical Support: 1-800-645-7492 (8 a.m.-6 p.m. E.S.T.)*

*West Coast Technical Support: 1-800-458-9469 (8 a.m.-5 p.m. P.S.T.)*

*Technical Support Fax Number: 1-800-447-5086*

*ATLIS-BBS Electronic Bulletin Board System: 1-516-496-3980*

*(1200 - 9600 Baud, 8 Data Bits, 1 Start/Stop Bit, No Parity)*

## TABLE OF CONTENTS

<p><b>I. GENERAL INFORMATION</b> ..... 5</p> <p>The 5140XM Control..... 5</p> <p>Easy Programming ..... 5</p> <p>Memory of Alarm ..... 5</p> <p>Built-in User's Manual &amp; Descriptor Review..... 5</p> <p><b>II. ZONE CONFIGURATIONS</b> ..... 6</p> <p>ZONE TYPE DEFINITIONS ..... 6</p> <p>BASIC 8 HARD-WIRED ZONES ..... 8</p> <p>    Zones 1 &amp; 2: 2-Wire Smoke Detectors..... 8</p> <p>    Zone 6: Alternate Tamper Function..... 9</p> <p>    Zone 7: Alternate Keyswitch Function..... 9</p> <p>    Zone 8: 2-Wire Glass Break Detectors..... 9</p> <p>2-WIRE POLLING LOOP EXPANSION..... 10</p> <p>    Advisories ..... 10</p> <p>    Polling Loop Smoke Detectors ..... 10</p> <p>    Misc. Polling Loop Devices..... 11</p> <p>SYSTEM ZONES ..... 12</p> <p><b>III. PERIPHERAL DEVICES</b>..... 13</p> <p>REMOTE CONSOLES ..... 13</p> <p>    Two Console Ports..... 13</p> <p>    Powering And Wiring ..... 14</p> <p>    Addressable Console DIP Switches ..... 14</p> <p>BELL CIRCUIT OUTPUTS..... 16</p> <p>    General Information..... 16</p> <p>    Power and Wiring..... 16</p> <p>AUXILIARY RELAY..... 17</p> <p>DIALER OUTPUTS..... 18</p> <p>TRIGGER OUTPUTS..... 19</p> <p>    General Information..... 19</p> <p>    Remote Console Sounder Operation..... 20</p> <p>    Remote Keyswitch Operation/Wiring ..... 21</p> <p>    5140LED Indicator Module ..... 22</p> <p>    Auxiliary Alarm Signaling Equipment..... 23</p> <p>    Event Logging Printer Connections..... 24</p> <p>    Direct Wire Downloading ..... 25</p> <p><b>IV. MOUNTING &amp; POWERING</b>..... 26</p> <p>    Mounting the Cabinet ..... 26</p> <p>    Mounting the Cabinet Lock..... 26</p> <p>    Mounting the Consoles..... 27</p> <p>    Adjusting the LCD Viewing Angle ..... 28</p> <p>POWERING THE SYSTEM ..... 29</p> <p>    AC Power..... 29</p> <p>    Earth Ground Connections..... 29</p> <p>    Battery Supervision ..... 30</p> <p>    Back-Up Power Calculations..... 30</p> <p>    Power-Up Procedure..... 30</p> <p>    Polling Loop Current Draw Worksheet..... 31</p> <p>    Total Standby/Alarm Load Worksheets..... 31</p> <p>    Battery Capacity Calculation Worksheet..... 32</p> <p>    Battery Selection Table ..... 32</p> <p><b>V. SYSTEM OPERATION</b>..... 33</p> <p>SECURITY ACCESS CODES ..... 33</p> <p>    Installer Code..... 33</p> <p>    Master/Manager Codes ..... 35</p> <p>    Operator Codes ..... 35</p> <p>    Duress Code ..... 35</p> <p>KEYPAD FUNCTIONS ..... 36</p> <p>    Arming Functions ..... 36</p> <p>    View Capabilities of a User ..... 37</p> <p>    Viewing Downloaded Messages..... 37</p> <p>    Using the Built-in User's Guide..... 37</p> <p>    Displaying Descriptors ..... 37</p> <p>    Panic Keys ..... 37</p>	<p><b>V. SYSTEM OPERATION (cont.)</b>..... 38</p> <p>FIRE SUPERVISORY &amp; TROUBLE CONDITIONS.. 38</p> <p>    Supervisory &amp; "Check" Message ..... 38</p> <p>    Power Failure ..... 38</p> <p>    Other Trouble Conditions..... 38</p> <p>SETTING THE REAL-TIME CLOCK ..... 39</p> <p>EVENT LOGGING PROCEDURES..... 40</p> <p>    Programming ..... 40</p> <p>    Display &amp; Print Modes..... 40</p> <p>    Clear Event Log..... 41</p> <p><b>VI. SYSTEM COMMUNICATION</b> ..... 42</p> <p>    Split/Dual Reporting..... 42</p> <p>    Ademco Low Speed..... 42</p> <p>    SESCOA/Radionics..... 42</p> <p>    4+2 Reporting..... 42</p> <p>    4+2 Express ..... 42</p> <p>    Ademco High Speed Reporting..... 43</p> <p>    Contact ID Reporting ..... 43</p> <p>    Table of Contact ID Event Codes..... 44</p> <p>    Communication Programming Guide..... 44</p> <p><b>VII. PROGRAMMING THE SYSTEM</b>..... 45</p> <p>GENERAL PROGRAMMING PROCEDURES..... 45</p> <p>    Communication Default Programming..... 45</p> <p>    Zone, Device &amp; Alpha Programming ..... 45</p> <p>    Programming Steps..... 45</p> <p>COMMUNICATION PROGRAMMING..... 47</p> <p>    Loading Defaults..... 47</p> <p>    Easy-to-Program Communication Fields ..... 47</p> <p>    Summary of Default Consequences..... 48</p> <p>PROGRAMMING DATA FIELDS ..... 49</p> <p>#93 MENU MODE ..... 50</p> <p>    Zone Programming ..... 50</p> <p>    Device Programming..... 50</p> <p>    Alpha Programming ..... 51</p> <p>    Entering Zone Descriptors ..... 51</p> <p>    Adding Custom Words..... 52</p> <p>    Creating a Custom Message..... 52</p> <p>    Vocabulary of Words in Memory..... 53</p> <p><b>VIII. DOWNLOADING PRIMER</b> ..... 54</p> <p><b>IX. TESTING THE SYSTEM</b> ..... 56</p> <p>    Battery Test..... 56</p> <p>    Dialer Test..... 56</p> <p>    Fire Drill Test..... 56</p> <p>    One Man Fire Walk Test..... 56</p> <p>    Burglary Waik Test..... 57</p> <p>    Armed Burglary Test..... 57</p> <p>    Turning the System Over to the User..... 57</p> <p><b>X. REGULATORY AGENCY REQUIREMENTS</b> 58</p> <p>    Misc. UL Requirments ..... 58</p> <p>    New York City Requirements ..... 58</p> <p>    — 4190WH OPERATION &amp; WIRING..... 59</p> <p>    — DIP SWITCH SETTING TABLES..... 60</p> <p>    — COMMUNICATION DEFAULTS..... 62</p> <p><b>XI. SPECIFICATIONS</b>..... 66</p> <p>    SUMMARY OF CONNECTIONS ..... 67</p> <p>    — PROGRAMMING FORM..... Centerfold</p>
--	---

## LIST OF FIGURES

### LIST OF FIGURES

1.	5140XM FIRE CONTROL SYSTEM .....	5
2.	ALARM SAF POWER SUPPLY CONNECTION DIAGRAM.....	14
3.	ADDRESSABLE CONSOLE.....	15
4.	BELL CIRCUIT WIRING .....	16
5.	AUXILIARY RELAY WIRING .....	17
6.	J2 PIN ASSIGNMENTS AND FUNCTIONS.....	19
7.	REMOTE CONSOLE SOUNDER WIRING .....	20
8.	KEYSWITCH WIRING .....	21
9.	5140LED INDICATOR MODULE WIRING .....	22
10.	7620ULF & 7920SE WIRING DIAGRAM.....	23
11.	346 POLARITY REVERSING RELAY WIRING.....	23
12.	445 HIGH LINE SECURITY DIRECT WIRE TRANSMITTER WIRING .....	23
13.	EVENT LOGGING PRINTER CONNECTIONS.....	24
14.	DIRECT WIRE DOWNLOADING CONNECTIONS.....	25
15.	CABINET ATTACK RESISTANCE CONSIDERATIONS.....	26
16.	SURFACE MOUNTING CONSOLES.....	27
17.	FLUSH MOUNTING CONSOLES.....	28
18.	ADJUSTING THE VIEW ANGLE.....	28
19.	BATTERY CONNECTION DIAGRAM.....	29
20.	4190WH WIRING DIAGRAM .....	59
21.	SUMMARY OF CONNECTIONS DIAGRAM.....	67

# I. GENERAL INFORMATION

## THE 5140XM CONTROL

The 5140XM offers the features of a UL listed commercial fire alarm and a commercial burglary alarm panel in one package. It may be used to provide either fire warning protection alone or both fire warning and burglary protection in commercial applications ranging from small stores to moderate sized factory/office complexes.

The 5140XM is a microprocessor based programmable panel which features EEROM memory technology (power loss does not result in the loss of panel programming). It allows up to sixteen 5137AD (gray)/5137ADR (red) consoles to be connected which provide audible/visual indications of system status and allow user entry of system commands. The 5140XM provides 8 class B (style B) zones and a built-in polling loop which allows the number of zones to be expanded to 64 using 2-wire polling loop devices. Zones may be programmed to provide manual fire alarm, automatic fire alarm with alarm verification, waterflow alarm, sprinkler system supervisory and various types of burglary protection. The 5140XM provides one built-in supervised dialer output for transmitting alarm and system status reports to a central station via the switched telephone network. It also allows an optional 5140DLM supervised back-up dialer module to be connected if required.

The 5140XM is designed to meet the following standards:

### Commercial Burglary:

UL609 Grade A local mercantile premises/safe and vault  
 UL 611/1610 Grades A, AA Central Station  
 UL 365 Grades A, AA Police Connect

### Commercial Fire:

UL 864/NPFA 72A local and  
 UL864/NPFA 71 central station

## EASY PROGRAMMING

The 5140XM can be programmed at the office prior to installation or on the job site directly from a console or from a laptop computer using the 4130PC downloading software and the 4100SM PC/panel serial interface module. It can also be programmed remotely over the switched telephone wires using a PC, the 4130PC software and a Hayes 1200 SMARTMODEM. For installer convenience, the panel is pre-programmed with a set of standard values that is designed to meet the needs of many installations. These values, however, can be changed to suit the needs of any particular installation. The panel can also be pre-programmed by the installer with one of four standard communication default programming values, eliminating the need for extensive programming time and effort.

## MEMORY-OF-ALARM

The Panel provides a memory-of-alarm feature, which, upon entering a security code to silence an alarm and/or to disarm the burglary portion of the system, automatically displays all zones that were in an alarm condition.

## BUILT-IN USER'S MANUAL AND DESCRIPTOR REVIEW

For end-user convenience, the 5140XM contains a built-in Users Manual. By depressing and holding any of the function keys on the console for 5 seconds, a brief explanation of that particular function scrolls across the alpha-numeric display. In addition, all programmed zone descriptors can be displayed (one at a time) by pressing and holding the READY key for 5 seconds, then releasing the key. This serves as a check for installers to be sure all descriptors are entered properly.

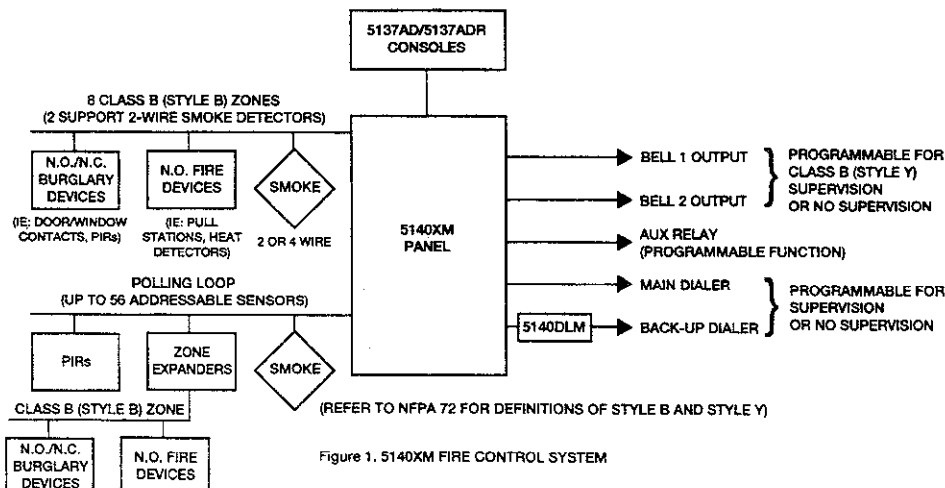

Figure 1. 5140XM FIRE CONTROL SYSTEM

## II. ZONE CONFIGURATIONS

### ZONE TYPE DEFINITIONS

The 5140XM System allows up to 64 zones of hard-wire and polling loop protection. Each zone must be assigned to a zone type, which defines the way in which the system responds to faults in that zone. In addition, there are several "system zones" for keypad panics, polling loop faults, etc. which must be assigned a zone type. See the "System Zone" section for a list of these zones.

- Type 00**  
**Zone Not Used** Program a zone with this zone type if the zone is not used.
- Type 01**  
**Entry/Exit #1 Burglary** This zone type provides entry delay whenever the zone is faulted if the control is armed in the Away or Stay modes. When the panel is armed in the Instant or Maximum modes, no entry delay is provided. Exit delay begins whenever the control is armed, regardless of the arming mode selected. These delays are programmable. This zone type is usually assigned to sensors or contacts on doors through which primary entry and exit will take place.
- Type 02**  
**Entry/Exit #2 Burglary** This zone type provides a secondary entry delay whenever the zone is faulted if the panel is armed in the Away and Stay modes. When the panel is armed in the Instant or Maximum modes, no entry delay is provided. Secondary exit delay begins whenever the control is armed, regardless of the arming mode selected. These delays are programmable. This zone type is usually assigned to sensors or contacts on doors through which secondary entry and exit will take place, and where more time might be needed to get to and from the console. Delay time must be greater than Zone type 1. (Ex.: a garage, loading dock, or basement door)
- Type 03**  
**Perimeter Burglary** This zone type gives an instant alarm if the zone is faulted when the panel is armed in the Away, Stay, Instant or Maximum modes. This zone type is usually assigned to all sensors or contacts on exterior doors and windows.
- Type 04**  
**Interior, Follower** This zone type gives a delayed alarm (using the programmed Entry/exit time) if the Entry/Exit zone is faulted first. Otherwise this zone type gives an instant alarm. This zone type is active when the panel is armed in the Away or maximum modes. Maximum mode eliminates the delay though. **This zone type is bypassed automatically when the panel is armed in the Stay or Instant modes.** This zone type is usually assigned to a zone covering an area such as a foyer, lobby, or hallway through which one must pass upon entry (After faulting the entry/exit zone to reach the console to disarm the system.) Since this zone type is designed to provide an instant alarm if the entry/exit zone is not violated first, it will protect an area in the event an intruder hides on the premises prior to the system being armed, or gains access to the premises through an unprotected area.
- Type 05**  
**Trouble by Day/Alarm by Night** This zone type will give an instant alarm if faulted when armed in the Away, Stay, Instant or Maximum (night) modes. During the disarmed state (day), the system will provide a latched trouble sounding from the console (and a central station report, if desired). This zone type is usually assigned to a zone which contains a foil-protected door or window (such as in a store), or to a zone covering a "sensitive" area such as a stock room, drug supply room, etc. This zone type can also be used on a sensor or contact in an area where immediate notification of an entry is desired.
- Type 06**  
**24-hour Silent Alarm** This zone type sends a report to the Central Station but provides no console display or sounding. This zone type is usually assigned to a zone containing an Emergency button.
- Type 07**  
**24-hour Audible Alarm** This zone type sends a report to the Central Station, and provides an alarm sound at the console, and an audible external alarm. This zone type is usually assigned to a zone that has an Emergency button.
- Type 08**  
**24-hour Auxillary Alarm** This zone type sends a report to Central Station and provides an alarm sound at the console. **(No bell output is provided).** This zone type is usually assigned to a zone containing a button for use in personal emergencies, or to a zone containing non-fire related monitoring devices such as water sensors, temperature sensors, etc.

**Type 09  
Supervised Fire (No  
Verification)**

Used for zones containing smoke detectors (when smoke alarm verification is not desired), or containing heat detectors, pull stations, etc. An open in this zone will initiate a trouble signal. A short in this zone will initiate a fire alarm.

**Type 10  
Interior w/Delay**

This zone type gives entry delay (using the programmed entry time), if tripped when the panel is armed in the Away mode. This zone type is also active during maximum mode, but no delay is provided (alarms occur immediately if zone is tripped). **This zone type is bypassed when the panel is armed in the Stay or Instant modes.** Delay begins whenever sensors in this zone are violated, regardless of whether or not an entry/exit delay zone was tripped first.

**Type 16  
Fire With Verification**

Used when smoke alarm verification is desired on hardwire and polling loop zones containing only 2-wire or 4-wire smoke detectors. An open will initiate a trouble response and a short initiates a fire alarm response. Initial short detection causes 6 second smoke detector power reset. Subsequent short detection within 90 seconds of reset causes fire alarm.

**Type 17  
Fire Waterflow**

An open in this zone causes a trouble response. Shorts which remain present for longer than the programmable time delay cause a fire alarm response.

**Type 18  
Fire Supervisory**

This type is assigned to a zone having sensors which monitor fire sprinkler systems (i.e. PIV switches, etc.). An open in this zone causes a trouble. Shorts which remain present longer than the programmable time delay cause a supervisory response. Supervisory response will not activate a bell output.

**Type 19  
24 Hour Trouble**

An open or short in this zone causes a trouble response. No external alarm sounders are actuated.



## BASIC 8 HARD-WIRED ZONES (Zones 1-8)

### GENERAL INFORMATION

All zones have a 350 milli-second response and can be assigned any zone type. All zones provide class B (style B) supervision using a 2K EOL resistor (m 610-7, supplied). The panel also supervises the zone wiring for earth ground faults.

When programmed for fire warning usage, all zones can monitor 4-wire smoke detectors (zone types 9, 16), N.O. fire alarm initiating devices (zone types 9, 17) or N.O. sprinkler system supervisory devices (zone type 18). When programmed for burglary usage, all zones can monitor N.O. or N.C. alarm initiating devices. Use any UL listed N.O. or N.C. device not requiring power from the panel. Use only those 4-wire smoke detectors listed below.

Note that power for 4-wire smoke detectors is supplied by the panel's auxiliary power #1 output and this power must be switched using the built-in auxiliary relay to allow the detectors to be reset via the second entry of an OFF sequence (i.e.: security code + OFF key) at a console following an alarm. Also note that a System Sensor A77-716-01 EOL relay module must be used to supervise the power connections to 4-wire smoke detectors. See the AUXILIARY RELAY section for programming and wiring information. Zones which are programmed for fire with alarm verification response (zone type 16) should only be used to monitor smoke detectors.

Connect N.C. devices **in series** with the zone wires and connect N.O. devices **across (in parallel with)** the zone wires. Observe polarity when wiring smoke detectors. Connect the 2K EOL resistor across the zone wires at the last device. The maximum zone resistance is 100 ohms for zones 1, 2 and 8 and 300 ohms for all other zones (excluding the 2K EOL resistor).

#### Compatible 4-Wire Smoke Detectors

You may use as many 4-wire smoke detectors as can be powered from the panel's auxiliary power 1 output without exceeding this output's rating (see the POWERING THE SYSTEM section for auxiliary power ratings)

Photoelectric, direct wire	System Sensor 2412
Photoelectric w/heat sensor, direct wire	System Sensor 2412TH
Ionization, direct wire	System Sensor 1412

### ZONES 1 & 2: 2-WIRE SMOKE DETECTORS

These zones have the added capability of supporting 2-wire smoke detectors. Each zone provides enough standby current (2 mA) to power up to sixteen of the smoke detectors listed below. Each zone provides only enough alarm current (20 mA) to power one smoke detector in the alarmed state. When assigned zone type 9 or 16, the second entry of an OFF sequence at a console will interrupt power to these zones to allow detectors to be reset following an alarm.

#### Compatible 2-Wire Smoke Detectors

You may use up to sixteen 2-wire smoke detectors on zone 1 and on zone 2 as found in the table below.

DETECTOR TYPE	DEVICE MODEL #
Photoelectric w/heat sensor, direct wire	System Sensor 2300T
Photoelectric, direct wire	System Sensor 2400
Photoelectric w/heat sensor, direct wire	System Sensor 2400TH
Photoelectric w/B401B base	System Sensor 2451
Photoelectric w/heat sensor and B401B base	System Sensor 2451TH
Ionization, direct wire	System Sensor 1400
Ionization w/B401B base	System Sensor 1451
Photoelectric duct detect. w/DH400 base	System Sensor 2451
Ionization duct detector w/DH400 base	System Sensor 1451DH

NOTE: These smoke detectors are Listed for use with the 5140XM and are the only 2-wire smoke detectors that may be used.

**ZONE 6:  
ALTERNATE TAMPER  
FUNCTION**

This zone may be programmed to serve as a tamper loop for the C-COM cabinet and for the Ademco AB12 grade A burglary bell box. For Grade A Burglary installations, field 3\*17 must be programmed to "1" to enable this function and zone 6 should be assigned a day/night burglary response (zone type 05). The panel will initiate a day trouble/night alarm when an open or short circuit is detected in this zone or when an earth ground fault caused by tampering with the AB12 burglary bell box is detected. See the BELL CIRCUIT OUTPUTS section for AB12 bell wiring information.

**ZONE 7:  
ALTERNATE  
KEYSWITCH FUNCTION**

This zone may be programmed to serve as a keyswitch input. See the REMOTE KEYSWITCH section for keyswitch programming, wiring and operating information.

**ZONE 8:  
TWO WIRE GLASS  
BREAK DETECTORS**

This zone has the added capability of supporting 2-wire latching type glass break detectors. Use detectors which are compatible with the ratings listed below. The second entry of an OFF sequence will interrupt zone power to allow detectors to reset following an alarm.

**Compatible 2-Wire Glass Break Detectors**

Standby Voltage: 5VDC - 14VDC

Standby Resistance: Greater than 20k ohms (equivalent resistance of all detectors in parallel)

Alarm Resistance: Less than 1.1k ohms (see note below)

Alarm Current: 2 mA - 10 mA

Reset Time: Less than 6 seconds

The IEI 735L series detectors have been tested and found to be compatible with these ratings. Up to 50 IEI 735L detectors, connected in parallel, may be used (the alarm current provided by this zone is sufficient to support operation of only one detector in alarmed state). Follow the manufacturer's recommendations on proper detector installation.

**NOTES:**

- Detectors which exceed 1.1k ohms in alarm, but maintain a voltage drop in alarm of less than 3.8 volts can also be used.
- Use of N.O. or N.C. contacts on the same zone may prevent proper glass break detector operation.

## 2-WIRE POLLING LOOP EXPANSION (Zones 9-64)

### GENERAL INFORMATION

The 5140XM provides a built-in 2-wire polling loop interface which allows the number of zones to be expanded from the basic 8 zones to up to 64 zones using various addressable polling loop sensors. The panel supervises the polling loop wiring for open, short and earth ground faults. See below for a list of compatible sensors and for comments regarding restrictions on burglary and fire usage.

The polling loop provides power to sensors and serves as a communication path between the panel and sensors. Each sensor must be assigned a unique address ID number (from 9-64) before being connected to the polling loop. Most sensors have DIP switches for this purpose. See the DIP SWITCH SETTING TABLE FOR POLLING LOOP DEVICES for information on how to assign ID numbers using DIP switches. Care must be taken to assign unique ID numbers to each sensor in order to allow the panel to supervise and provide unique console status indications for individual sensors.

Sensors can be connected to a single run, or groups of sensors may be connected to separate wire runs without affecting the panel's ability to supervise individual sensors. Follow the wiring instructions provided with individual sensors (4190WH wiring diagram is provided at the end of this manual). Be sure to observe sensor polarity when wiring. The maximum allowable wire run length between the panel and the last sensor on a given wire run is as follows:

#### Polling Loop Wire Run Lengths

Gauge	Maximum Length
#22	650 feet
#20	950 feet
#18	1500 feet
#16	2400 feet

NOTE: Twisted pair recommended for all normal wire runs.

**IMPORTANT:** The maximum combined polling loop run is 4000'. If using shielded wire, the maximum is 2000'. If longer wire runs are needed, a 4197 Loop Extender Module must be used.

### INTERCOM INTERFERENCE

If an intercom system is being used, the polling loop wires must be as far from the intercom wiring as possible (minimum 6"). If this spacing cannot be achieved, shielded wire must be used. If this is not done, interference on the intercom system might occur. Also note that the maximum total wire length supported is cut in half when shielded wire is used.

### ADVISORIES

The maximum allowable current draw on the polling loop is 64mA. Refer to the POLLING LOOP CURRENT DRAW WORKSHEET (found in the POWERING THE SYSTEM section) for current draws of various polling loop devices. If more than 64mA is being drawn, use of the 4197 provides another loop with 64mA available.

Make certain to include the total current drawn on the polling loop in the Total Standby/Alarm Load Worksheet (see POWERING THE SYSTEM section) when figuring the total auxiliary load on the panel's power supply.

### POLLING LOOP SMOKE DETECTORS

Can be added to the 2-wire Polling Loop on zones 9 through 64 (as programmed in fields \*03, \*04, \*05, 1\*01, 1\*02, 1\*03, 1\*04 and 1\*05). These detectors have a built-in RPM which is DIP switch programmable. They are wired in parallel to the polling loop, and do not need auxiliary power or a separate reset switch. The polling loop provides power and reset signals to the detectors, as well as alarm and trouble signals from the detectors.

#### 4192SD Photoelectric Polling Loop Smoke Detector

Direct wire photoelectric smoke detector with built-in RPM which is DIP switch programmable.

#### 4192SDT Photoelectric Polling Loop Smoke Detector w/Heat Detector

Direct wire photoelectric smoke detector with 135°F (57°C) heat detector, and built-in RPM which is DIP switch programmable.

#### 4192CP Ionization Smoke Detector

Direct wire products of combustion ionization detector with built-in RPM which is DIP switch programmable.

**PASSIVE INFRARED  
MOTION DETECTORS**

Refer to the PIR Installation Instructions for installation hints as to the best mounting location for these devices.

**4278 Quad Element Polling Loop PIR**

Quad element PIR with built-in RPM which is DIP switch programmable and connects directly to the polling loop. Includes mirrors for both wide angle and curtain/long range applications. NOTE: The built-in auxiliary sensor loop is not supervised and should not be used.

**4275 Dual Element Polling Loop PIR**

Dual element PIR with built-in RPM which is DIP switch programmable. Includes mirrors for both wide angle and curtain/long range applications and can use the 1875PA Pet Alley mirror. Built-in selectable pulse count capability.

**MISCELLANEOUS  
POLLING LOOP  
DEVICES**

**4194 Surface Mounted Reed Contact (Wide Gap)**

Wide gap surface mounted reed contact with built-in RPM, which is DIP switch programmable.

**4190WH Two Zone Remote Point Module**

Used to supervise conventional N.O./N.C. devices via the polling loop, and has a tamper supervised cover.

Provides one class B (style B) supervised (left) loop for monitoring fire alarm, sprinkler supervisory and burglary sensors. NOTE: N.O. fire/sprinkler devices must be (style B) supervised using a 4.7k EOLR (model 610-11; purchased separately as part of 4100EOLR Resistor Kit). N.O. and N.C. burglary devices may be supervised using either a 4.7k or 30k EOLR. Note that the second unsupervised (right) loop should not be used. DIP switch programmable zone number.

**4208 Eight Zone Polling Loop Expansion Module**

Used to supervise conventional N.O./N.C. devices via the polling loop. Provides 8 class B (style B) supervised loops for monitoring fire alarm, sprinkler supervisory and burglary sensors.

NOTE: The first six loops are (style B) supervised using a 4.7k EOLR and can monitor either N.O. fire alarm/sprinkler supervisory devices or N.O./N.C. burglary devices. The last two loops are supervised using a 30k EOLR and can only be used to monitor N.O./N.C. burglary devices.

Note that the 4208 must either be mounted inside the 5140XM cabinet or in a separate enclosure which has a tamper supervised cover when used to monitor burglary devices.

DIP switch programmable zone numbers. The first two loops can be selected for either normal or fast response (DIP switch selectable).

**4197 Polling Loop Extender Module**

At present, the 4197 is UL Listed for burglary applications only. Can be used if the 2-wire polling loop must be greater than the recommended length (4000' max). By installing a 4197 at the end of the first loop, the polling loop can be continued. If more than 64mA needs to be drawn from the polling loop to power RPMs, use of the 4197 provides another loop with 64mA available. Connects to the polling loop and must be powered from auxiliary power #1 output.

**GENERAL  
INFORMATION**

**SYSTEM ZONES (Zones 70 - 99)**

Aside from the 64 hardwire and polling loop sensor zones, the 5140XM provides a number of additional zones which are dedicated to monitoring various aspects of system behavior. These system zones are listed below. The "system zone" number appears in the console display window when a fault condition associated with this zone is detected. The zone types programmed in field 3\*10 (for zones 70-75) and field \*05 (for zones 95-99) determine the panel's response to "system zone" faults.

- Zone #70: Bell Output 1: Monitors bell 1 output's supervision status (if enabled at installation time). See the BELL CIRCUIT OUTPUTS section for more information.
- Zone #71: Bell Output 2: Monitors bell 2 output's supervision status (if enabled at installation time). See the BELL CIRCUIT OUTPUTS section for more information.
- Zone #72: Earth Ground: Monitors the panel's field wiring to determine if an earth ground fault exists. This zone's default type is set to [19] (24 hour trouble) to provide a trouble response to earth ground faults. When the panel detects an earth ground fault caused by tampering with (i.e.: drilling through) the Ademco AB12 grade A burglary bell box, it overrides the zone 72 fault response and instead triggers a zone 6 alarm (if enabled in field 3\*17).
- Zone #73: J2 Input: Monitors the status of Input 1 on the main PCB J2 header. Input 1 can be used to monitor the "Xmit Okay" signal from the 7620ULF LORRA. See the TRIGGER OUTPUTS section for more information.
- Zone #74: Dialer Line 1: Monitors the supervision status of the main dialer output (if enabled at installation time). See the DIALER OUTPUTS section for more information.
- Zone #75: Dialer Line 2: Monitors the supervision status of the optional 5140DLM back-up dialer module's output (if installed/enabled at installation time). See the DIALER OUTPUTS section for more information.
- Zone #76: Auxiliary Relay: Assigned to the built-in auxiliary relay for the purposes of allowing the operation of this relay to be bypassed. Since the auxiliary relay is not supervised, this zone does not monitor anything and cannot be assigned a zone type.
- Zone #77: LORRA Triggers: Assigned to the LORRA triggers on the main PCB J2 header for the purposes of allowing the operation of these triggers to be bypassed. Since the LORRA triggers are not supervised, this zone does not monitor anything and cannot be assigned a zone type.
- Zone #95: Keypad Panic: Activated by simultaneous depression of the console [\*] and [1] keys. See the KEYPAD FUNCTIONS section for more information.
- Zone #96: Keypad Panic: Activated by simultaneous depression of the console [#] and [3] keys. See the KEYPAD FUNCTIONS section for more information.
- Zone #97: Polling Loop Short: Monitors the polling loop wiring for short circuit faults. See the POLLING LOOP section for more information.
- Zone #99: Keypad Panic: Activated by simultaneous depression of the console [\*] and [#] keys. See the KEYPAD FUNCTIONS section for more information.

### III. PERIPHERAL DEVICES

#### REMOTE CONSOLES

##### GENERAL INFORMATION

The 5140XM panel interfaces to 5137AD (gray bezel) and 5137ADR (red bezel) alpha custom LCD consoles. These consoles provide visual and audible indication of system status and allow the user to enter system operating commands. These consoles provide the following features:

- 2-line, 32 character (16 characters per line) alpha numeric LCD display which provides a programmable "English Language" description for each zone.
- 12 key telephone style keypad. The keys are back-lit.
- Built-in sounder which provides audible indications of alarm, fire supervisory and trouble conditions.
- Choice of gray or red front bezel.

NOTE: Many municipalities require that fire system annunciators be red in color. Check with the authority having jurisdiction before choosing a console color for your installation.

- 90 mA current draw.

##### TWO CONSOLE PORTS

The 5140XM provides 2 console interface ports. Port 1 uses terminals 11-14 on the main PCB terminal block and port 2 uses pins 1, 4, 5,, 7 on the main PCB J4 connector as indicated below. The port 2 power/data wires are electrically isolated from (i.e. not affected by open, short or earth ground faults on) port 1 power/data wires. Note that the 4142TR nine wire cable (1 cable supplied) is used to make connections to the J4 connector.

##### Port 1

terminal 11: aux power #1 output (to console red wire)  
terminal 12: ground (to console black wire)  
terminal 13: data in 1 (to console green wire)  
terminal 14: data out 1 (to console yellow wire)

##### Port 2

J4/pin 1: ground (to console black wire)  
J4/pin 4: data in 2 (to console green wire)  
J4/pin 5: aux power #2 output (to console red wire)  
J4/pin 7: data out 2 (to console yellow wire)

When only 1 console will be used in the installation, this console must be mounted on or near the cabinet (see the MOUNTING THE CONSOLES section) and may be wired to either port. When more than 1 console will be installed, the "main" console must be mounted on or near the cabinet and must be wired to Port 2. The "supplementary" consoles can be mounted where desired and must be wired to Port 1. The "main" console will continue to function even when wiring faults prevent the "supplementary" consoles from operating properly. Note that the panel can detect earth ground faults on Port 1 and 2 wiring but does not supervise this wiring for open and short circuit faults.

## POWERING AND WIRING

The 5140XM supports, independent of auxiliary power considerations, up to sixteen 5137AD/5137ADR consoles. The 5140XM can supply up to 1 amp of auxiliary standby power for consoles, polling loop devices, motion detectors, 4-wire smoke detectors, etc. (the maximum auxiliary standby load that can be drawn is limited by the capacity of the backup battery used. A 1 amp load requires a 4 AH battery. See the POWERING THE SYSTEM section for more information). Provided that the maximum permissible standby load is not exceeded, up to 11 consoles (at 90mA per console) can be powered from the panel's auxiliary power 1 and auxiliary power 2 outputs. Keep this in mind when adding consoles so that the panel's power supply is not overloaded resulting in a battery which does not properly charge.

If the panel's maximum permissible standby load is exceeded, then additional consoles and/or other auxiliary devices can be powered from a separate UL Commercial Listed power supply. The Alarm-Saf model AS/PS5-BFS-12-UL Commercial Fire Listed supply can be used to power additional consoles and/or other auxiliary fire devices. The diagram below shows how to make connections to the Alarm-Saf power supply.

Figure 2. ALARM - SAF POWER SUPPLY CONNECTION DIAGRAM

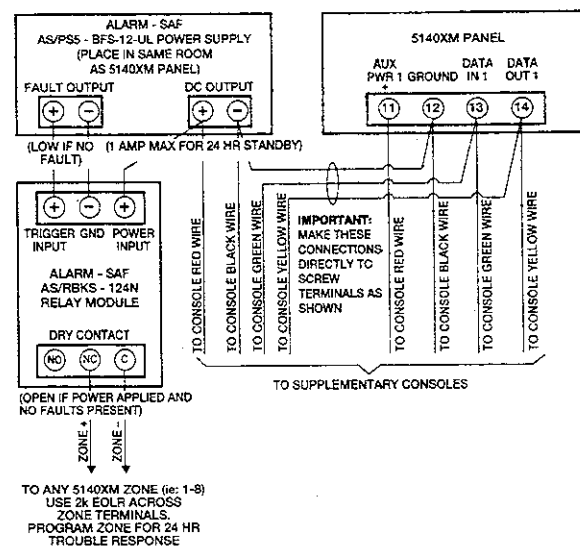

Supplementary consoles may be wired to a single wire run or individual consoles may be connected to separate wire runs. The maximum wire run length from the panel to a console which is homerun back to the panel must not exceed:

### CONSOLE WIRE RUN LENGTHS

Gauge	Maximum Length
#22	450 feet
#20	700 feet
#18	100 feet
#16	1750 feet

If more than one console is wired to a single run, then the above maximum lengths must be divided by the number of consoles on the run (i.e. the maximum length would be 225 feet if two consoles are wired on a #22 gauge run).

NOTE: The length of all wire runs combined must not exceed 2000 feet when unshielded quad conductor cable is used (1000 feet if shielded cable is used.)

The 5137AD and 5137ADR consoles are addressable devices. They have a built-in DIP switch which is used to select their operating address. Each console used must be assigned a unique address for proper system operation. Refer to the figure and table below to set this DIP switch. The panel can be programmed to tell it what sounding options should be used for each console (refer to DEVICE PROGRAMMING in the PROGRAMMING THE SYSTEM section for more information). The panel's standard factory default enables all console addresses and sets each console for no sounder suppression. You only need to use the Device Programming Mode at initial installation if you desire to change the sounder options for one or more consoles.

NOTE: Some versions of the 5137AD/5137ADR consoles have a sixth DIP switch. Make sure that the sixth switch is in the DOWN position.

## ADDRESSABLE CONSOLE DIP SWITCH SETTINGS

## CONSOLE DIP SETTINGS

ID	DIP SETTINGS				
	1	2	3	4	5
0	dn	dn	dn	dn	dn
1	dn	dn	dn	dn	UP
2	dn	dn	dn	UP	dn
3	dn	dn	dn	UP	UP
4	dn	dn	UP	dn	dn
5	dn	dn	UP	dn	UP
6	dn	dn	UP	UP	dn
7	dn	dn	UP	UP	UP
8	dn	UP	dn	dn	dn
9	dn	UP	dn	dn	UP
10	dn	UP	dn	UP	dn
11	dn	UP	dn	UP	UP
12	dn	UP	UP	dn	dn
13	dn	UP	UP	dn	UP
14	dn	UP	UP	UP	dn
15	dn	UP	UP	UP	UP
16	UP	dn	dn	dn	dn
17	UP	dn	dn	dn	UP
18	UP	dn	dn	UP	dn
19	UP	dn	dn	UP	UP
20	UP	dn	UP	dn	dn
21	UP	dn	UP	dn	UP
22	UP	dn	UP	UP	dn
23	UP	dn	UP	UP	UP
24	UP	UP	dn	dn	dn
25	UP	UP	dn	dn	UP
26	UP	UP	dn	UP	dn
27	UP	UP	dn	UP	UP
28	UP	UP	UP	dn	dn
29	UP	UP	UP	dn	UP
30	UP	UP	UP	UP	dn
31	UP	UP	UP	UP	UP

**NOTE:**

The Standard Default enables all console addresses (0-30).

**NOTE:** Some versions of the 5137AD/5137ADR console may have a 6 position DIP switch. The sixth switch should be put in the DOWN position.

**ADDRESS "31"**

Do not use address 31. Address 31 causes the console to operate in non-addressable mode (i.e. works like a standard, non-addressable 5137 console).

DIP SWITCH ON PCB

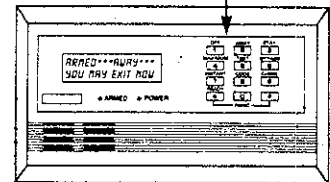

FRONT VIEW

TOP VIEW

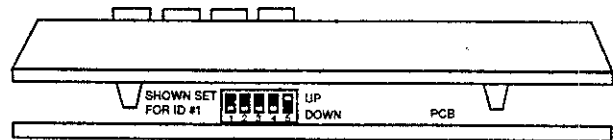

ADDRESSABLE CONSOLE



## BELL CIRCUIT OUTPUTS

### GENERAL INFORMATION

The 5140XM provides two bell circuit outputs for operating fire and burglary alarm indicating devices (bell 1 - terminals 3, 4 and bell 2 - terminals 5, 6). Each output may be independently selected for the following features:

- class B (style Y) supervision (used for fire bell circuits) using a 2K EOL resistor (model 610-7, supplied) or no supervision (used for burglary bell circuits). System zone 70 monitors the supervision status of the bell 1 output and system zone 71 monitors the supervision status of the bell 2 output. The panel's response to faults on these outputs is determined by the zone type programmed in field 3\*10 for the corresponding system zone.

NOTE: Cut the white jumper W1 (W4) on the main PCB and program zone 70 (zone 71) for no response to disable supervision for bell 1 (bell 2). No EOLR required.

- activation by alarm conditions on one, some or all protection zones (fields 3\*70 through 3\*81)
- short ding for confirmation of arming (field \*16 for bell 1, 3\*57 for bell 2) and for entry/exit or perimeter zone faults while CHIME mode is active (field 1\*47 for bell 1, 3\*59 for bell 2)
- activation in a steady or pulsing manner in response to alarm condition (field 3\*15)
- 2 to 30 minute timeout or no timeout (field \*13 for bell 1, 3\*60 for bell 2). Note: burglary bell circuits must be programmed for 16 (or more) minute timeout.

### POWER AND WIRING

Each bell output is rated as follows: 10VDC - 14VDC, 2.3 amps max., power limited. Note that the total alarm current drawn from the aux power 1, aux power 2, bell 1 and bell 2 outputs cannot exceed 2.3 amps for battery independent operation.

By default, bell 1 is set to operate as an unsupervised burglary bell output. You may use any UL listed, non-polarized burglary indicating device rated for 10 -14 VDC operation on this output. Note that a local burglary grade A listing requires that a bell in a tamper protected housing be used (such as the Ademco AB12) and that bell wiring be run in conduit. By default, bell 2 is set to operate as a supervised fire bell output. Note that the panel supervises this wiring for open, short and earth ground faults. You may use any UL listed, polarized fire indicating device rated for 10 -14 VDC operation on this output. Observe polarity when wiring polarized devices. Some examples of compatible devices are given below. The diagram shows how to make connections to these outputs.

#### Examples of Compatible Alarm Indicating Devices

Burglary	Bells	Ademco AB12 (grade A bell/housing)
Fire	Bells	Ademco WFP8-12 (8" bell) Ademco WFP10-12 (10" bell)
	Horns	System Sensor PA400R (red piezo horn) System Sensor MA-12/24 (red horn)
	Strobes	System Sensor MA/SS-12 (horn and strobe) System Sensor SS-12

Figure 4. BELL CIRCUIT WIRING  
(Shows wiring for bell outputs configured using factory default programming selections)

- BELL 1 FACTORY DEFAULTS**  
Bell 1 is configured as a burglary bell circuit
- Use non-polarized Grade A indicating devices (eg: Ademco No. AB12 - see below)
  - Wiring is not supervised; cut white jumper, W1, on main PCB
  - Activates for zones 3-8 alarms
  - Steady alarm output
  - 16 minute timeout
- BELL 2 FACTORY DEFAULTS**  
Bell 2 is configured as a fire bell circuit
- Use polarized indicating devices
  - Class B open/short supervision
  - 24 hr trouble response to faults
  - Activates for zone 1, 2 alarms
  - Pulsed alarm output
  - No timeout

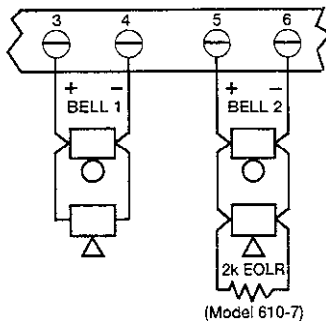

#### AB12 BELL/BOX WIRING

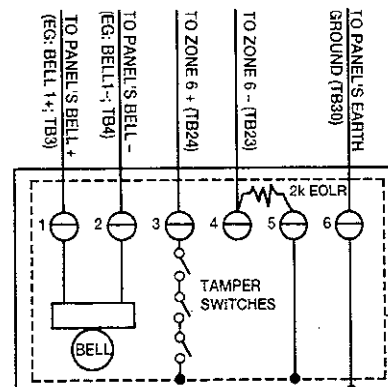

#### AB12 WIRING NOTES:

- Disconnect the AB12's factory wired connection from its terminal #4 to the outer box
- Set field 3\*17 to "1" to enable zone 6 tamper function
- Zone 6 should be programmed for a day trouble/night alarm (type or 24 hour alarm (type response
- Wire panel's door tamper switch in series with zone 6
- All wiring from AB12 to panel must be run in conduit

## AUXILIARY RELAY

The 5140XM provides a built-in "Form C" relay with contacts rated at 28 VAC/VDC, 2.8 amps max. This relay may be programmed for one of the functions below (field 3\*61):

- **Alarm Activation:** Steady activation in response to an alarm on one, some or all zones as selected in fields 3\*70 through 3\*81. If field 3\*61 is set to "1", the auxiliary relay remains activated until timeout (which is programmed independent of the bell 1 and bell 2 timeouts; field 3\*60) or until the security code + OFF has been entered. If field 3\*61 is set to "4", the auxiliary relay remains activated until the installer or master code + [#] +67 is entered.

When this function is used, the auxiliary relay can be used for elevator recall or ventilator shutdown on fire alarms or when wired to the aux power 1 output or to a separate power supply (such as Alarm-Saf model AS/PS5-BFS-12-UL; see the REMOTE CONSOLES section), the auxiliary relay can be used to provide a third (unsupervised) bell output for supplementary strobes, sounders, etc. as indicated in the diagram, below. By default, the auxiliary relay is set to activate on zone 1 - 8 alarms with no timeout (field 3\*61=1) as might be required for a common fire and burglary alarm strobe indicator usage.

When field 3\*61=1, the auxiliary relay can also be programmed to give a brief activation for confirmation of arming (field 3\*57) or for entry/exit or perimeter zone faults while CHIME mode is active (field 3\*59).

- **Trouble/Supervisory Activation:** Steady activation in response to any zone or system related trouble condition or to any fire supervisory condition. Remains activated until all fault conditions have been corrected and the security code + OFF has been entered.
- **4-Wire Smoke Detector Reset:** Momentary (6 second) activation at second entry of OFF sequence which interrupts power to 4-wire smoke detectors connected to hard-wired zones (zones 1-8) or to polling loop zones, allowing the detectors to be reset following an alarm. Power to 4-wire smoke detectors should be wired to the auxiliary relay and to the auxiliary power 1 output as shown in the diagram below.
- **Battery Saver:** When this function is selected, the auxiliary relay will normally be activated (i.e. N.O. and pole contacts will be connected, N.C. contact will be open) and will de-activate 4 hours after the start of an AC power failure. Using this feature, non-critical loads (such as supplementary consoles) which do not need to be supported for the full 24 hour battery backup period can be disconnected from the auxiliary outputs, allowing a smaller capacity battery to be used. The relay re-activates within a few seconds after AC power restores.

Figure 5a. AUXILIARY RELAY WIRING  
(Shows how to wire Aux Relay for unsupervised, powered alarm output.)

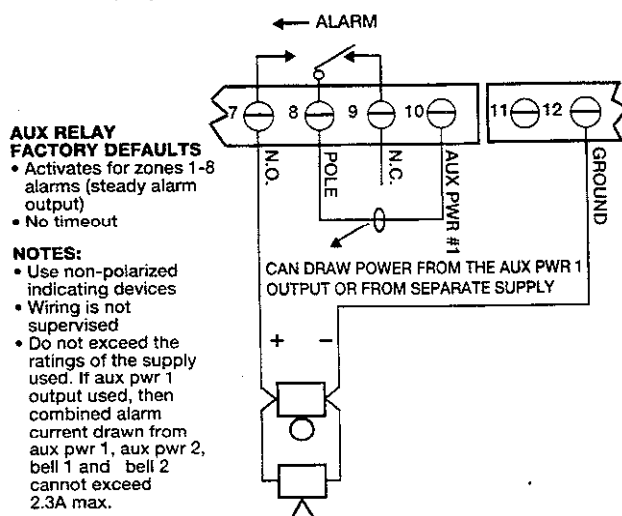
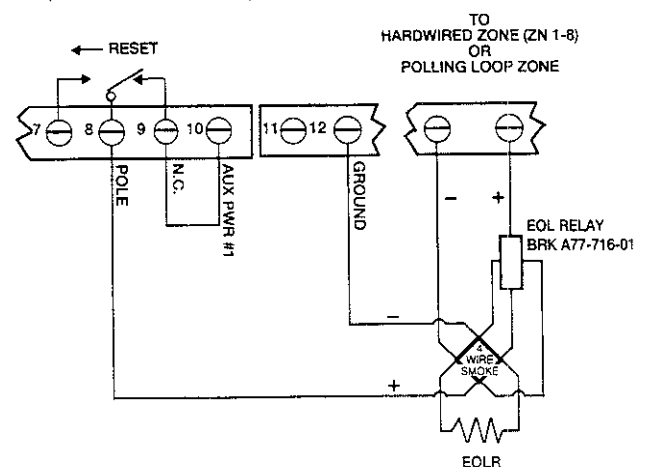

Figure 5b. AUXILIARY RELAY WIRING  
(Shows how to wire aux relay for 4-wire smoke detector power reset)



## DIALER OUTPUTS

The 5140XM provides one built-in main dialer output, with voltage and current supervision, which can be programmed to use either rotary (default) or TouchTone dial formats. The 5140XM also allows for connection of an optional 5140DLM back-up dialer module. This module provides a second supervised dialer output which serves as a back-up to the main output. The 5140DLM mounts to the main PCB shield and connects to the main PCB J3 connector using a ribbon cable (supplied with module) as shown in the SUMMARY OF CONNECTIONS diagram at the end of this manual. Note: the earth ground screw on the 5140DLM must be connected to the earth ground screw (terminal 30) on the main PCB using 16 AWG wire. For Listed Fire Central Station (UL864/NFPA 71) applications, use either a LORRA alone, the main dialer with the LORRA, or use the main dialer with the 5140DLM Backup Dialer.

Connect the main and back-up dialer (if used) outputs to telephone company lines which provide loop start service using the RJ31X cables supplied. DO NOT connect both outputs to the same telephone company line. Connection to telephone company lines which provide ground start service is not permitted.

System zones 74 and 75 monitor the supervision status of the main and back-up dialer outputs respectively. The panel's response to faults on these outputs is determined by the zone type programmed in field 3\*10 for the corresponding system zone. By default, zone 74/main dialer is programmed for 24 hour trouble response (type 19) and zone 75/back-up dialer is programmed for no response (type 00). The supervision circuits on both dialer outputs will trip a fault when the tip/ring voltage falls below approx. 25 volts (13 volts for the main dialer when the main PCB blue jumper is cut; 13 volts for the back-up dialer when it's blue jumper is cut) and when handset current is less than approx. 10 mA. Note: The blue jumper should be cut when the dialer outputs are connected to telephone lines which have a telephone company MTU installed.

When only the main dialer is enabled ([1,0] in field 3\*30), the 5140XM will attempt to route all calls over the main output. When both main and back-up dialers are enabled ([1,1] in field 3\*30), the 5140XM will attempt to route all calls over the main output until a fault is detected, at which time it will attempt to use the back-up output. Line faults will result in a zone 74-DIALER 1 FAULT or a zone 75-DIALER 2 FAULT display. The communicator will make up to 8 attempts to transmit a report to one or both telephone numbers, depending upon the report routing option programmed. After the eighth attempt, the communicator will hang up and a COMM FAIL will be displayed at the console. The dialer attempts are programmed in field 3\*21 (default=8; must be restricted to 3, 4 or 5 attempts if a secondary phone number is programmed).

The 5140XM will transmit reports in the following order: alarms (fire, medical/panic, burglary), fire supervisories and troubles, remaining types of messages. See the SYSTEM COMMUNICATION section for a description of the variety of communication formats and the types of messages transmitted by the panel and for the dialer programming defaults.

**WARNING:** To prevent the risk of shock, disconnect phone lines at telco jack before servicing the panel.

### IMPORTANT

If the communicator is connected to a telephone line inside a PABX, be sure the PABX has a back-up power supply that can support the PABX for 24 hours. Many PABXs are *not* power backed up and connection to such a PABX will result in a communication failure if power is lost.

**GENERAL INFORMATION**

**TRIGGER OUTPUTS**

The J2 connector, located in the upper right hand corner of the main PCB, provides 1 input (labeled INPUT 1) and seven trigger outputs (labeled OUT 1 - OUT 7) that can be used to interface to the following:

- Remote console sounder
- UL Listed keyswitch
- 5140LED Indicator Module
- Auxiliary alarm signaling equipment such as the Ademco 7620ULF Subscriber Radio
- Event logging serial printer (via 4100SM Module)
- PC computer used to direct wire download the panel's operating parameters (via 4100SM Module)

The pin assignments for the J2 connector are shown in the diagram below. Use a 4142TR 9-wire trigger cable (1 supplied) to make connections to this connector. The panel does not supervise field wiring connected to this connector.

The trigger output ratings are listed below. Note: all outputs are power limited.

**Outputs 1, 5, 7:**      LOW: 2K to ground  
                                   HIGH: 10-14 VDC @ 20 mA max

**Remaining Outputs:** LOW: 1K to ground  
                                   HIGH: 10-14 VDC through 5K

Program fields 3\*19 & 3\*20 are used to select the functions of INPUT 1 and OUT 1-7 as indicated in the diagram below.

Figure 6. J2 PIN ASSIGNMENTS AND FUNCTIONS

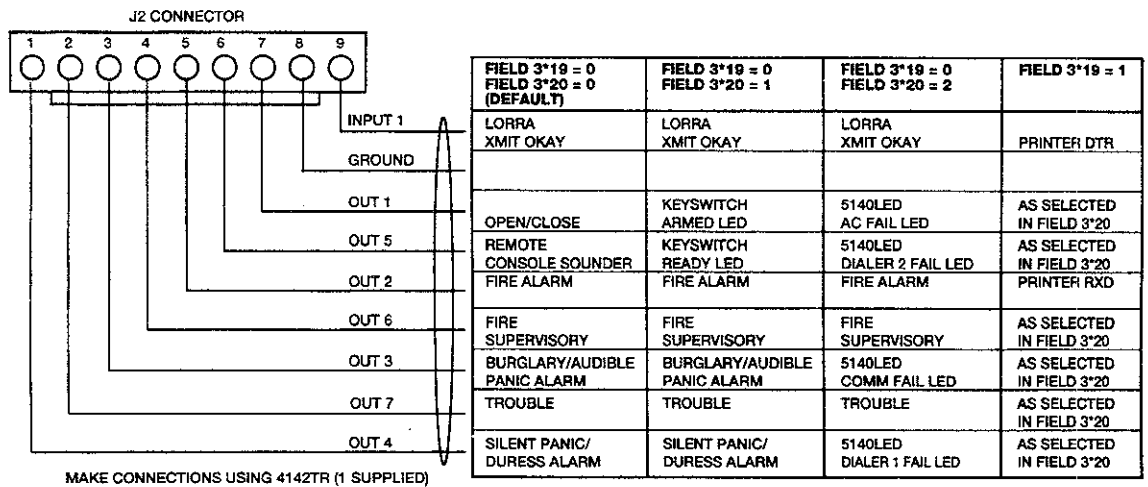

**REMOTE CONSOLE  
SOUNDER  
OPERATION/WIRING**

An optional Amseco PAL 328N piezo sounder can be used for installations where it is desired to remote the sounds produced by the console's built-in sounder. The panel will remote all sounds (i.e. alarm, trouble, chime, entry/exit, etc.) produced by the console's built-in sounder except for the short key clicks associated with console key depression. One application of this feature might be to produce chime sounds in a location which is distant from the panel's consoles. If used, program field 3\*20 must be set to "0" (factory default) to enable the remote sounder option, and the PAL 328N must be connected to J2/OUT 5 as shown in the Remote Console Sounder diagram.

Figure 7. REMOTE CONSOLE SOUNDER WIRING

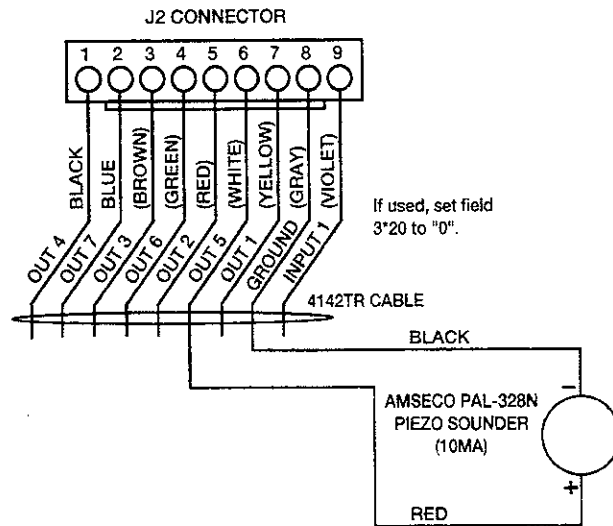

## REMOTE KEYSWITCH OPERATION/WIRING

An optional UL Listed remote keyswitch can be used for remote arming/disarming of the burglary portion of the system and for remotely silencing alarms. If used, program field \*15 must be set to "1" or "2" to select a keyswitch operating mode. Zone 7 must be assigned a non-zero response type. Also, field 3\*20 must be set to "1" if it is desired to use J2/OUT 1, 5 to operate keyswitch ARMED and READY LEDs (if keyswitch provides LEDs). The keyswitch's normally open momentary switch and LEDs (if used) must be connected to zone 7 and to J2/OUT 1,5 respectively as shown in the diagram below. An optional closed circuit tamper switch (ex. Ademco No. 112) can be wired in series with zone 7 so that keyswitch operation will be disabled when the switchplate is removed from the wall.

The 5140XM allows 2 modes of keyswitch operation. When field \*15 is set to "1", the keyswitch operates as follows:

### With System Disarmed and No Alarms Present:

A momentary short across zone 7 will arm the system in the AWAY mode, and a short held for more than 3 seconds will arm the system in the STAY mode. A subsequent short will disarm the system. The keyswitch LEDs will indicate that the system has armed (see table below). NOTE: Faulted zones must either be corrected or bypassed before the system will arm.

### With Alarms Present:

A momentary short across zone 7 will silence alarm bell and console sounds, and will disarm the system if it was armed. The keyswitch LEDs will provide a memory of alarm indication (see table below). A subsequent short across zone 7 will clear the alarm memory indication and reset 2-wire smoke and glass break detectors (if used).

When field \*15 is set to "2", the keyswitch operates as follows: A momentary short across zone 7 will silence alarm bell sounds (i.e. turn off Bell 1, Bell 2 and aux relay if programmed for alarms) only if a fire alarm is present. Outputs remain silenced until a code + OFF is entered to reset alarms and clear alarm displays. A momentary short has no effect if there are no fire alarms present. This mode is intended to be used where it is desired to provide the fire department with keyswitch silence capability without compromising the burglary system's security.

### LED indications are defined as follows:

GREEN	RED	MEANING
OFF	OFF	DISARMED & NOT READY
ON	OFF	DISARMED & READY
OFF	ON STEADY	ARMED AWAY
OFF	SLOW FLASH	ARMED STAY
OFF	RAPID FLASH	ALARM MEMORY

NOTE: Open/close reporting for keyswitch is enabled in field \*40, and the keyswitch reports as user 0.

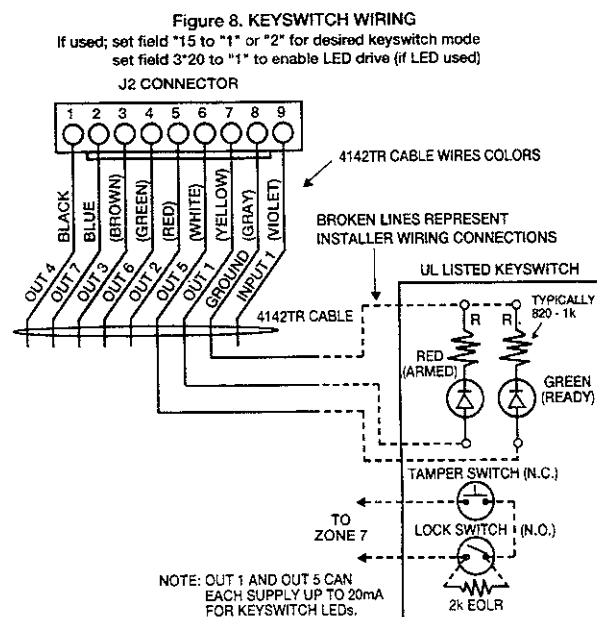

## 5140LED INDICATOR MODULE

An optional 5140LED Indicator Module can be used in municipalities which require dedicated indicators for communicator fault status. The 5140LED provides the following indicators:

- AC POWER: ON if AC power is present.  
OFF if AC power is not present.
- COMM FAILURE: ON if maximum number of attempts were made (field 3\*21) to transmit a message to the central station. Enter security code + OFF following a successful transmission to turn off.  
OFF if normal.
- DIALER 1 FAULT: ON if the main dialer line is faulted. Correct problem and then enter security code + OFF to turn off.  
OFF if normal.
- DIALER 2 FAULT: ON if the backup dialer line is faulted. Correct problem and then enter security code + OFF to turn off.  
OFF if normal.

If used, program field 3\*20 must be set to "2" to enable this option, and the 5140LED module must be connected to J2/OUT 1, 3, 4, 5 as shown in the diagram below. The 5140LED is designed to be mounted into a standard single gang electrical box. Follow the steps below to install this module.

1. Pull wires from the panel's J2 connector through an opening in the single gang box and splice these wires to the module's flying leads. Solderless splices may be used.
2. Mount the module's PC board onto one side of the PC board retainer bracket (supplied).
3. Slide the PC board retainer bracket into the box and fasten with screws (supplied).
4. Mount the stainless steel decorative cover (supplied) onto the box.

Figure 9. 5140 LED INDICATOR MODULE WIRING  
If used, set field 3\*20 TO "2"

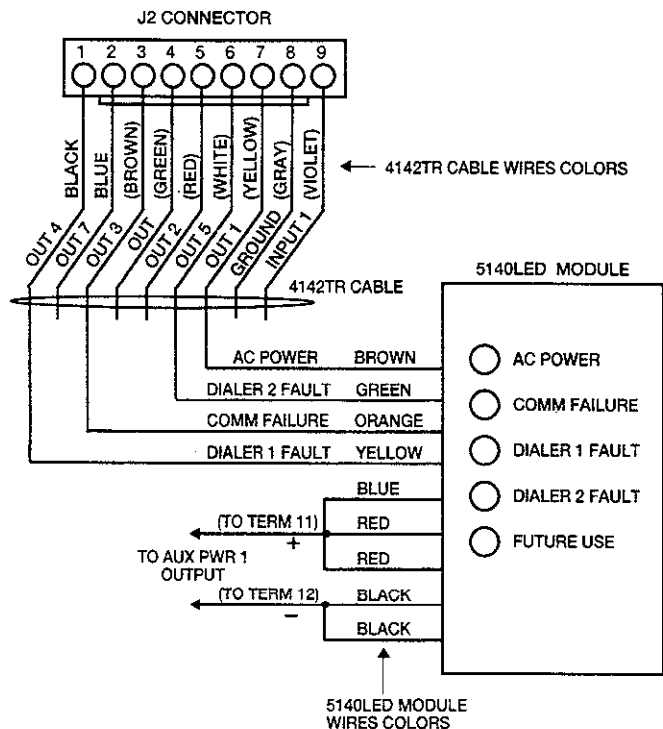

# AUXILIARY ALARM SIGNALING EQUIPMENT

The J2 connector provides triggers for fire alarm, burglary/audible panic alarm, silent panic/duress alarm, fire supervisory, trouble and open/close triggers. These triggers may be used to trip auxiliary alarm signaling equipment such as Ademco's 7620ULF, 7720 and 7920SE Long Range Radios, 346 polarity reversing relay and 445 high line security transmitter. Note that not all of these triggers are available for all setting of field 3\*20. Consult the J2 PIN ASSIGNMENTS AND FUNCTIONS diagram shown earlier.

The open/close trigger is LOW when the burglary system is armed, and HIGH when disarmed. The remaining triggers are normally LOW and go HIGH when the corresponding fault condition occurs. The fire, burglary/audible panic and silent panic/duress alarm triggers remain HIGH until the security code + OFF is entered. The fire supervisory and trouble triggers remain HIGH until the fault condition is removed and the security code + OFF is entered.

The diagrams below show how to make connections to the 7620ULF, 7920SE, 346 and 445. Consult the UL INSTALLATION CHECKLIST section for a description of the specific 5140XM trigger connections and programming options required for each of the various UL Listings.

Figure 10. 7620 ULF WIRING DIAGRAM

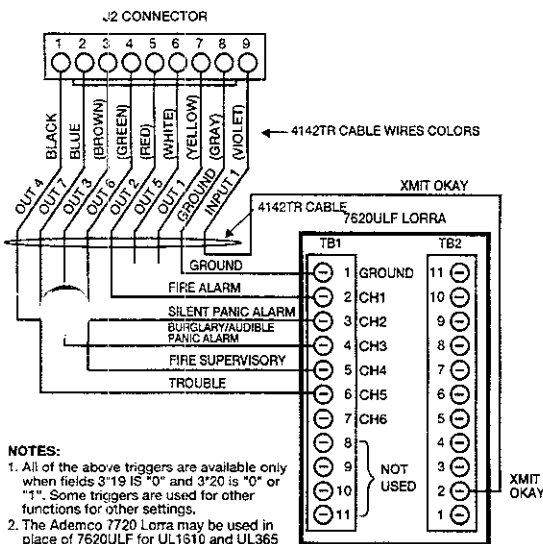

- NOTES:**
- All of the above triggers are available only when fields 3\*19 is "0" and 3\*20 is "0" or "1". Some triggers are used for other functions for other settings.
  - The Ademco 7720 Lorra may be used in place of 7620ULF for UL1610 and UL365 installations.
  - Refer to the 7620ULF installation instructions for Lorra mounting and programming information.
  - Mount the 7620ULF within 3 feet of the 5140XM panel. Run wiring from panel to 7620ULF in conduit.

Figure 11. POLARITY REVERSING RELAY WIRING

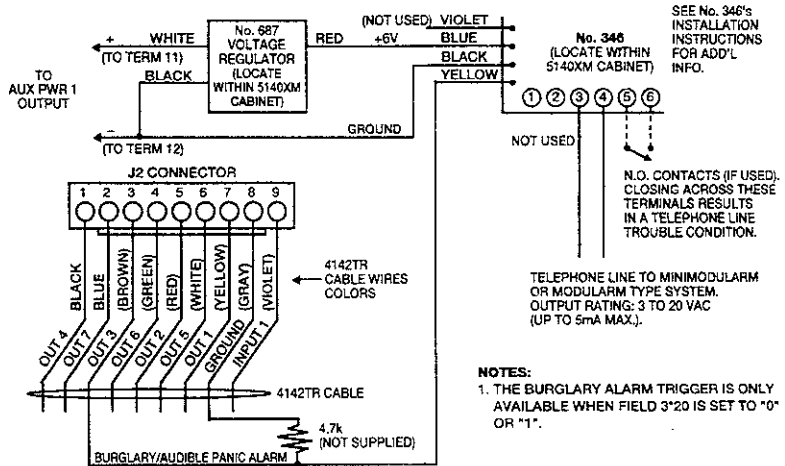

- NOTES:**
- THE BURGLARY ALARM TRIGGER IS ONLY AVAILABLE WHEN FIELD 3\*20 IS SET TO "0" OR "1".

Figure 12. 445 HIGH LINE SECURITY DIRECT WIRE TRANSMITTER WIRING

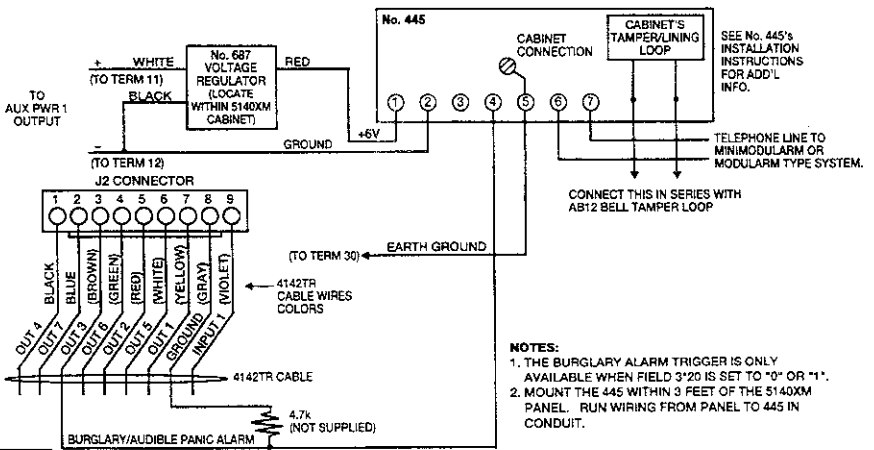

- NOTES:**
- THE BURGLARY ALARM TRIGGER IS ONLY AVAILABLE WHEN FIELD 3\*20 IS SET TO "0" OR "1".
  - MOUNT THE 445 WITHIN 3 FEET OF THE 5140XM PANEL. RUN WIRING FROM PANEL TO 445 IN CONDUIT.

7920SE WIRING DIAGRAM

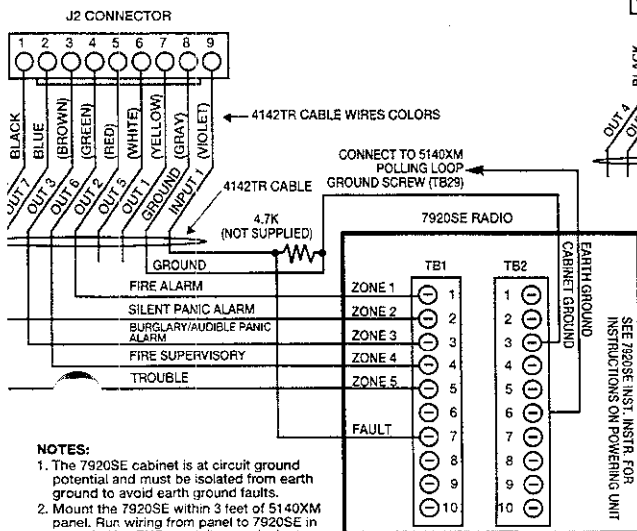

- NOTES:**
- The 7920SE cabinet is at circuit ground potential and must be isolated from earth ground to avoid earth ground faults.
  - Mount the 7920SE within 3 feet of 5140XM panel. Run wiring from panel to 7920SE in conduit. Use PVC conduit or equivalent means to isolate circuits of each unit.



## EVENT LOGGING PRINTER CONNECTIONS

The 5140XM allows its event log to be printed on a local serial printer. If used, program field 3\*19 must be set to "1". NOTE: This setting overrides the functions selected for INPUT 1 and OUT 2 made in field 3\*20. Connect a UL EDP Listed serial printer to the J2 connector using an Ademco 4100SM Interface module as shown below. Refer to the EVENT LOGGING PROCEDURES section of this manual for a description of the console commands which initiate event log printing.

NOTE 1: Printer must be configured as follows:

- 8 data bits, no parity, 1 stop bit
- 300 or 1200 baud (1200 preferred)
- Hardware handshaking using DTR signal

NOTE 2: The 4100SM module is supplied with a 10 foot RS232 cable. A longer cable or an extension cable can be used if the 5140XM and serial printer are separated by more than 10 feet, but the total cable length should be less than 50 feet.

NOTE 3: Most printers either ignore the CTS, DSR and CD signals, or require them to be high (i.e. 3-15VDC as measured on RS232 DB25 connector pins 5, 6 & 8 respectively with respect to ground pin 7). The 4100SM module sets these pins high. If the printer being used will not operate with these pins high, then clip the blue (CTS), white (DSR) or red (CD) jumpers on the 4100SM module to set the corresponding signal floating. Important pins on the RS232C cable are pin 3 (data out), pin 7 (ground) and pin 20 (DTR - ready).

NOTE 4: The DTR signal, as measured at 4100SM TB1, should be high (9.5-14VDC) when the printer is powered, properly connected, on-line and ready to print. This signal will be low (0-1.5VDC) when the printer is not powered, not properly connected, off-line or out of paper. The 5140XM will not send printing data to the printer unless the DTR signal is high.

NOTE 5: If earth ground fault sensing is enabled:

You may get an earth ground fault indication when the 4100SM module is clipped directly onto a sidewall of the 5140XM cabinet. If this occurs, use an insulator to insulate the 4100SM's clip-on bracket from the 5140XM cabinet side wall. Later production versions of the 4100SM have the clip-on bracket isolated from the circuit ground (terminal 7) and will not have this problem.

You may also get an earth ground fault indication if you use a printer (or PC) which has a 3-prong, grounded power cord. If this occurs, first verify that pin 1 (chassis ground) is isolated from pin 7 (signal ground) on the 4100SM's RS232 connector (early production versions of the 4100SM have an unmarked, 3/8" long, bare wire jumper lying near the pin 1 side of the RS232 connector which must be cut to isolate these pins). Then verify that these pins are isolated on your printer's RS232 connector. Follow the instructions provided with your printer to isolate these pins if required.

Figure 13. EVENT LOGGING PRINTER CONNECTIONS  
If used, set field 3\*19 to "1"

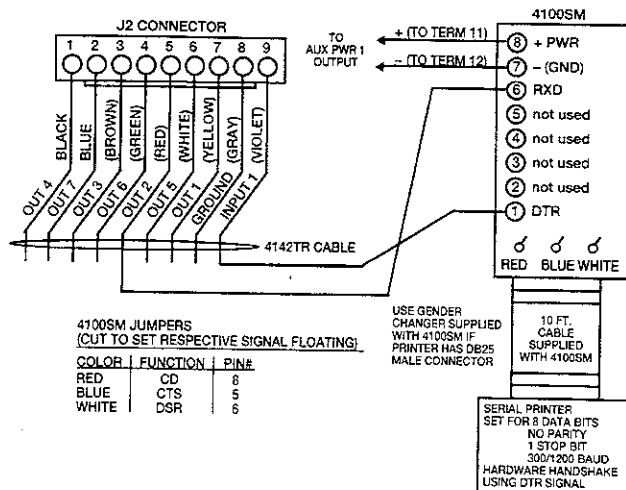

## DIRECT WIRE DOWNLOADING

The 5140XM can be downloaded without using a modem or telephone line by using 4130PC Downloading Software and a 4100SM Serial Module. This method of downloading is referred to as DIRECT WIRE downloading. Connect a PC which runs the downloading software to the 4100SM module as specified in the module's instructions. Connect the 4100SM to the panel's J2 header as shown below.

**IMPORTANT: The connections between the 5140XM and the 4100SM are different than those shown in the 4100SM Installation Instructions. See diagram below for correct connections. In addition, when the "green" wire is referred to in step 2 of the IN CASE OF DIFFICULTY section of the 4100SM Instructions, use the "violet" wire.**

Note also that the 4100SM violet wire connection for **computer terminals** differs from that used when connecting a **serial printer**.

Direct wire downloading can be initiated by following the procedures described in the 4100SM' instruction sheet.

Figure 14. DIRECT WIRE DOWNLOADING CONNECTIONS

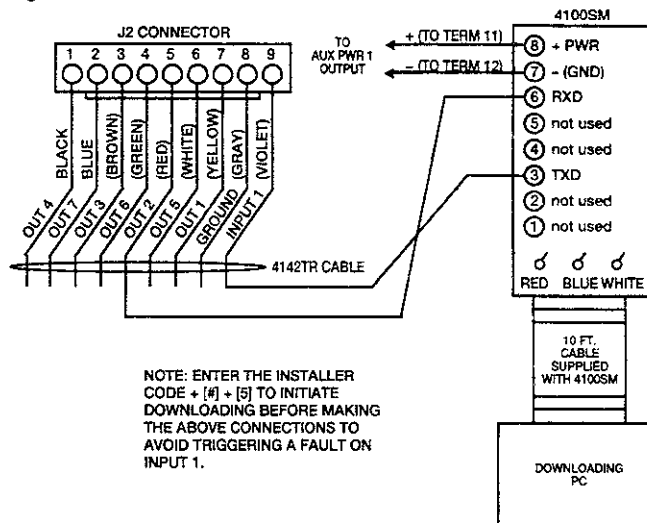

## IV. MOUNTING AND POWERING THE SYSTEM

### MOUNTING THE CABINET

Mount the cabinet to a sturdy wall using fasteners or anchors (not supplied) in a clean, dry area which is not readily accessible to the general public. The back of the cabinet has 4 holes for this purpose. Installations which are intended to provide listed burglary service have special attack resistance considerations for mounting the cabinet which are described below.

#### Grade A Mercantile Premises Listing

- The panel door must be supervised. Mount the clip-on tamper switch (supplied) to the cabinet's right side wall as shown in the diagram below and wire it to zone 6.
- Use a bell with a tamper protected housing such as the Ademco AB12. The bell housing's tamper switch and inner tamper linings must also be wired to zone 6.
- Program zone 6 for day trouble/night alarm (type 5, field \*02)) response and enable the zone 6 alternate tamper function (field 3\*17).
- All wiring between the bell and panel must be run in conduit. Remaining wires do not need to be run in conduit.
- All wiring which is not run in conduit must exit from the knock-out openings on the bottom or back of the cabinet.
- All unused knockouts must be plugged using the disc plugs and carriage bolts, supplied, as indicated in the diagram below
- Fasten the cabinet door to the cabinet backbox using the 18 one inch long philips heads screws (supplied) after all wiring, programming and checkout procedures have been completed

#### Grade A Mercantile Safe and Vault Listing

- Follow the instructions given above for Mercantile Premises listing, except as noted below.
- Mount a shock sensor such as Sentrol No. 5402 to the panel's backbox. Follow the manufacturer's instructions on proper sensor mounting. This sensor must also be wired to zone 6.

### MOUNTING THE CABINET LOCK

1. Insert the key into the lock. Position the lock in the hole making certain that the latch will make contact with the latch bracket when the door is closed.
2. While holding the lock steady, insert the retainer clip into the retainer slots. Position clip as illustrated in the diagram to facilitate easy removal.

### ADVISORY

Make certain that the PCB mounting screws are reasonably tight to insure that there is a good ground connection between the PC board and the cabinet. Also, dress field wiring away from the microprocessor (center) section of the PC board. The cabinet provides 2 loops on its left and right sidewalls for anchoring field wiring using tie wraps. These steps are important to minimizing the risk of panel RF interference with television reception.

Figure 15. CABINET ATTACK RESISTANCE CONSIDERATIONS  
(Shows typical local Grade A listing installation)

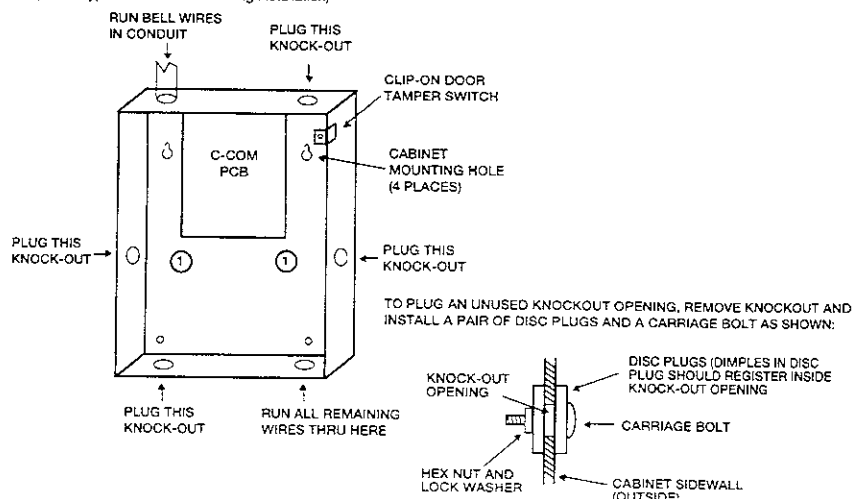

## MOUNTING THE CONSOLES

### GENERAL INFORMATION

As indicated in the REMOTE CONSOLES section, at least one console (i.e.: the "main" console) must either be mounted on the cabinet door or mounted on an electrical box located near (within 3 feet of) the cabinet. Run wires in conduit between the electrical box and the cabinet. Follow the SURFACE MOUNTING instructions, below, when mounting this console. Additional supplementary consoles can be surface or flush mounted where desired and do not require the use of an electrical box.

### SURFACE MOUNTING

1. Remove the console's back cover. The securing screw at the front of the console must be removed to release the back cover as shown in the diagram below.
2. For Dry Wall: using the back cover as a guide, make holes in the dry wall for the console mounting screws and interface wiring. Pass the wiring through the opening in the back cover, then mount this cover to the wall surface.  
For Cabinet Door: use a 1/4" drill bit to enlarge the 3 holes on the door. Mount the back cover to the door using 2 holes for console mounting screws and 1 hole for interface wiring.  
For Electrical Box: using the electrical box as a guide, make holes in the back cover for the console mounting screws and interface wiring. Pass the interface wiring through the opening in the back cover, then mount this cover to the box.
3. Splice the interface wiring to the console wires. Insulated solderless wire splices (i.e.: 311) may be used for splicing.
4. Attach the main body of the console to the mounted back cover. The console is properly attached when it snaps into place. Use the securing screw (previously removed) to secure the console to the back cover .

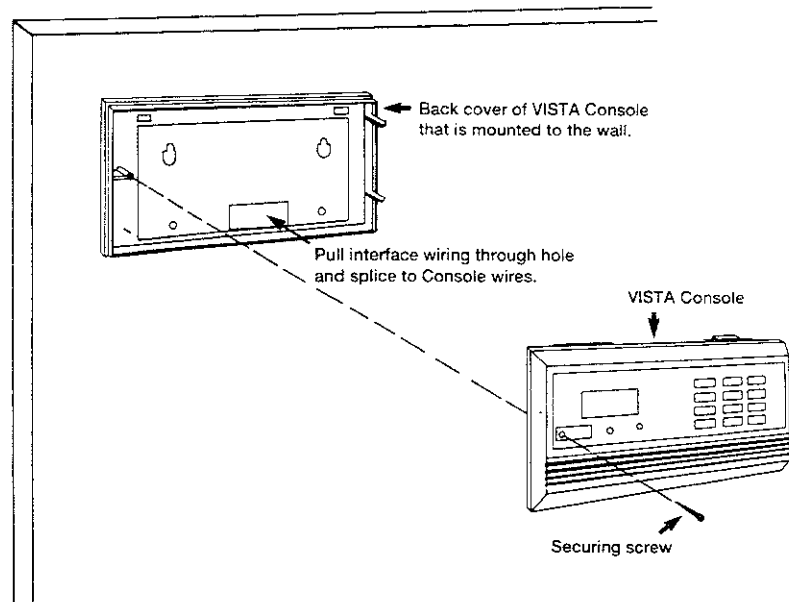

Figure 16. SURFACE MOUNTING CONSOLES

**FLUSH MOUNTING  
WITH TRIM RING KIT  
(5137TRK)**

1. Cut out a 4-3/4" high by 8" wide opening in the wall between studs, no less than 1-1/2" from either stud. Use the template provided to mark the cut-out.
2. Insert the four 1-1/2" long #6 screws through the mounting holes in the Trim Ring and then attach the four metal securing clips, as shown in the diagram. Use only two or three turns of each screw, allowing the metal clips to sit freely. The clips must not protrude beyond the sides of the Trim Ring or you will not be able to install the Trim Ring into the cut-out in the next step.
3. Install the trim ring into the opening in the wall with the hinge clasps to the right. Making sure the trim ring is straight, tighten each clip screw, making sure that the attached clip slides down into its guide track.
4. Install the Console as follows: Engage the hinge clasps on the trim ring with the notches located in the back (right-hand side) of the Console's front panel. Swing the left side of the panel toward the trim ring (the panel will pivot on the hinge clasps), and press firmly until the panel "snaps" closed.
5. Use the panel securing screw (supplied with the Console) to secure the left side of the panel.

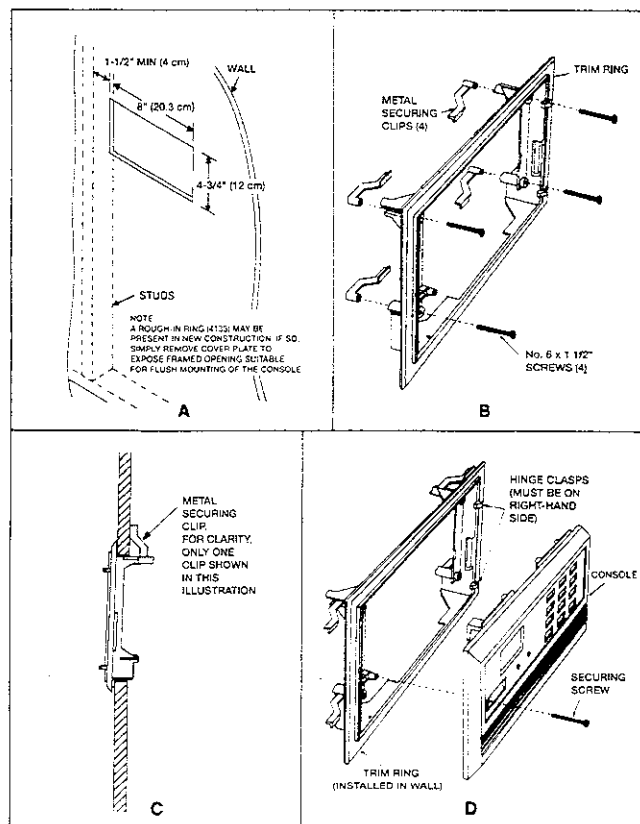

Figure 17. FLUSH MOUNTING CONSOLES

**ADJUSTING THE  
ALPHA CONSOLE LCD  
VIEWING ANGLE**

Insert the end of the small, key-shaped tool (supplied) into the small hole to the left of the console display window (the adjustment screw is recessed in this hole). Turn the adjustment screw to the left or right until optimum viewing is achieved. Be sure to take the height of the users into account when making this adjustment.

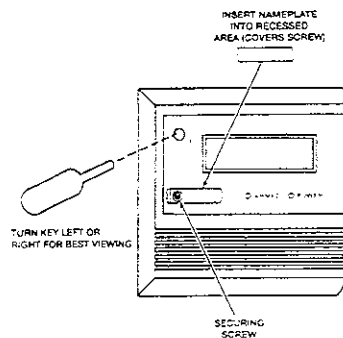

Figure 18. ADJUSTING VIEW ANGLE

## POWERING THE SYSTEM

### AC POWER

The Ademco 1451 transformer with enclosure (supplied) is used to supply AC power to the 5140XM panel. The 1451 consists of a transformer (with 120 VAC/1.0 Amp primary, 18 VAC/72 VA secondary rating), and a manually resettable circuit breaker mounted inside a protective enclosure.

1. Remove the front cover of the enclosure.
2. Mount the enclosure to the wall near the 5140XM panel. The enclosure has 4 mounting holes on its back surface for this purpose.
3. Run 120VAC wiring to the enclosure in conduit. NOTE: A dedicated circuit must be used. Use wire nuts to splice the 120VAC wires to the transformer's white and black primary leads. Connect the earth ground post on the back of the enclosure to a good earth ground (see EARTH GROUND CONNECTIONS below).
4. Use wire nuts to splice the transformer blue secondary leads to 16AWG wire which is run in conduit to the panel. These wires are connected to panel terminals 1 & 2.

NOTE 1: Use wires having insulation rated for at least 90°C operation and suitable for non-power limited applications.

NOTE 2: Use care to keep 18VAC wiring separated from all other wiring inside the panel's enclosure. This must be done by running non-power limited 18VAC wiring into the panel's enclosure via one of the knockouts on the left hand side of the enclosure, and then tie wrapping these wires to the tie wrap loops located near the knockout.

5. Replace the front cover of the enclosure and fasten with the screws supplied.

### PANEL EARTH GROUND CONNECTIONS

Connect the earth ground post inside the 1451 enclosure to a good earth ground (use grounding methods specified in the National Electric Code). Run a 16AWG wire from this post to the panel's earth ground terminal (terminal 30). This method of connection avoids ground loops that may occur when the 1451 and panel are connected to different earth ground systems. NOTE: The panel requires this connection in order for it's lightning transient protection devices and earth ground supervision to function properly.

#### NOTE: WHEN CONNECTING BATTERIES IN PARALLEL:

- USE BATTERIES FROM THE SAME MANUFACTURER AND WITH THE SAME VOLTAGE AND CAPACITY RATING.
- USE BATTERIES WITH APPROXIMATELY SAME AGE AND STATE OF CHARGE.
- USE CABLES PROVIDED AND **OBSERVE POLARITY!**
- IT IS RECOMMENDED THAT ALL BATTERIES BE REPLACED AT SAME TIME, EVEN IF ONLY ONE BATTERY HAS BECOME WEAK.
- AS LONG AS ONE GOOD BATTERY REMAINS CONNECTED, THE ONCE PER 60 SECOND BATTERY TEST WILL NOT DETECT THE DISCONNECTION OF REMAINING BATTERIES.

Figure 19. BATTERY CONNECTION DIAGRAM

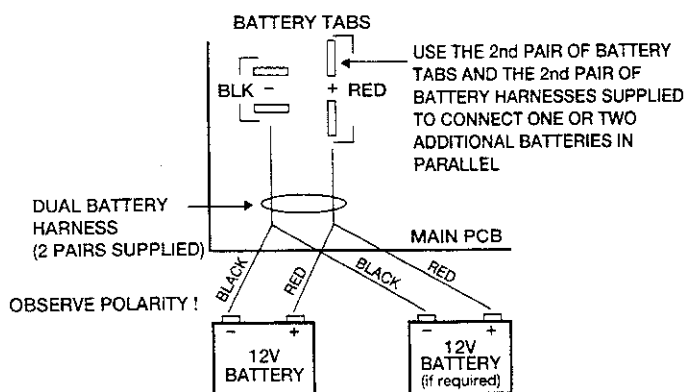

## **BATTERY SUPERVISION**

As a function of the 5140XM control, battery voltage is monitored once every 60 seconds. Under normal conditions the battery voltage should be approximately 13.65VDC. If battery voltage drops below approx. 11.5 volts, a low battery message is sent to the central station and annunciated on the local console. Battery lead supervision can be tested from the panel. The recommended procedure is to disconnect the battery harness from the 5140XM at the tab locations found on the left side of the 5140XM. Within 60 seconds a low battery signal will be sensed and the control begins communicating the information to the central station.

## **BACK-UP POWER CALCULATIONS**

The panel provides a circuit for float charging a 12 VDC, 12 AH min/34.4 AH max lead acid (gel cell) back-up battery. The float charging voltage is set to approx. 13.7 VDC. UL requires that the battery's capacity be sized to provide 24 hours of standby time for fire or for combination fire/burglary applications. This can be done as follows:

1. Fill out the POLLING LOOP CURRENT DRAW WORKSHEET, shown on next page, to determine the total current drawn from the polling loop (skip this step if polling loop not used).
2. Fill out the TOTAL STANDBY/ALARM LOAD WORKSHEET, shown on next page, to determine the total standby and alarm load drawn from the panel's power supply.
3. Fill out the BATTERY CAPACITY CALCULATION WORKSHEET, shown on next page, to determine the required capacity for the backup battery. Select one of the batteries given in the BATTERY SELECTION TABLE, shown on the next page.

## **POWER-UP PROCEDURE**

Connect all zone, polling loop, console, auxiliary device and bell circuit wiring. Wire and plug-in the 1451 transformer. After a few seconds the console's green POWER indicator should light. If not, check that the 1451 transformer is supplying proper voltage to the panel (about 17-19.5VAC when the power line voltage is 110-120VAC).

Measure the voltage across the "+" and "-" battery terminals on the main PCP to check that there is proper float charging voltage (13.5-13.8VDC). If not, auxiliary power terminals may have been loaded in excess of their ratings. Connect the back-up battery(s) using the battery harness(es) supplied as shown below. The panel performs a brief test every 60 seconds to determine if there is a battery connected, and performs an extended test every 24 hours to check the battery's condition, and provides a "SYSTEM LOBAT" indication when it finds that the battery voltage is low (less than approx. 11.5VDC; see the TESTING THE SYSTEM section for more information). Batteries which are low in voltage may take up to 48 hours to fully recharge.

The consoles will display the installer's message (default message is "DISARMED-READY TO ARM") if all zones are intact and there are no system problems. If not displayed, correct zone and system problems as needed.

**POLLING LOOP CURRENT DRAW WORKSHEET**

Refer to the POLLING LOOP section for device restrictions for fire and burglary usage.

RPM DEVICE	CURRENT	# OF UNITS	TOTAL
4194 Contact	1mA		
4192SD Photo Smoke	0.4 mA		
4192SDT Smoke w/Heat	0.4 mA		
4192CP Ion Smoke	0.4 mA		
4275 Dual PIR	1.0mA		
4196 Quad PIR	1.0mA		
4278 Quad PIR	1.0 mA		
4190 2-Zone RPM	1 mA (LOW);		
4190 2-Zone RPM	2 mA (HIGH)		
4208 8-Zone RPM	16 mA		
<b>TOTAL Cannot exceed 64mA*</b>			

\* The total current cannot exceed 64mA. If total load exceeds 64mA, then a 4197 loop extender module can be used. This module is powered from the panel's auxiliary power and provides a separate polling loop output which can support an additional 64mA load. Note that the 4197 is listed for commercial burglary use only and that the total number of points connected to the panel cannot exceed 56.

**TOTAL STANDBY/ALARM LOAD WORKSHEETS**

To calculate the total current for the Aux. power 1, Aux power 2, bell 1 & bell 2 outputs and polling loop current, multiply the each device's standby and/or alarm current by the number of units used.

- 1) Enter devices used on aux. power 1 output, calculate standby and alarm currents, then add to get aux. power 1 current subtotal.

AUX. POWER 1 OUTPUT				Total Current	
Device Model #	Device Current X	# of Units	=	Standby	Alarm
Aux. Power 1 Output Subtotal (terminals 10 & 11)				1.0A max	2.3A max

- 2) Enter devices used on aux. power 2 output, calculate standby and alarm currents, then add to get aux. power 2 current subtotal.

AUX. POWER 2 OUTPUT				Total Current	
Device Model #	Device Current X	# of Units	=	Standby	Alarm
Aux. Power 2 Output Subtotal (connector J4-pin 5)				400mA max	400mA max

- 3) Enter devices connected to bell 1 output, calculate alarm currents, then add to get bell 1 output current subtotal.

BELL 1 OUTPUT				Total Current	
Device Model #	Device Current X	# of Units	=	Standby	Alarm
				XXXXXX	
				XXXXXX	
				XXXXXX	
				XXXXXX	
				XXXXXX	
				XXXXXX	
				XXXXXX	
Bell 1 Output Subtotal (terminals 3 & 4) 2.3amp max				XXXXXX	



- 4) Enter devices connected to bell 2 output, calculate alarm currents, then add to get bell 2 output current subtotal.

BELL 2 OUTPUT Device Model #	Device Current X	# of Units	Total Current	
			Standby	Alarm
			XXXXXX	
			XXXXXX	
			XXXXXX	
			XXXXXX	
			XXXXXX	
			XXXXXX	
			XXXXXX	
Bell 2 Output Subtotal (terminals 5 & 6) 2.3amp max			XXXXXX	

- 5) Enter the total polling loop current using values calculated in the polling loop worksheet.

POLLING LOOP	Total Current	
	Standby	Alarm
(Enter worksheet total in both standby & alarm columns) Polling Loop Subtotal		

- 6) Enter the calculated subtotals of all listed outputs then add to get combined current.

COMBINED AUX. POWER, BELL AND POLLING LOOP	Total Current	
	Standby	Alarm
Aux. Power 1 Output Subtotal		
Aux. Power 2 Output Subtotal		
Bell 1 Output Subtotal		
Bell 2 Output Subtotal		
Polling Loop Subtotal		
Add all subtotals (Cannot exceed 1.0 amp max. standby; 2.3 amp max. alarm)		

- 7) These values are fixed.

5140XM PCB CURRENT	Total Current	
	Standby	Alarm
Includes 2-wire smoke detector loading on zones 1 & 2 and trigger output currents	300mA	470mA
5140DLM Back-up Dialer Module	5mA (inactive)	15mA (active)

\*5140DLM actually draws 55mA when active. However, since 5140XM PCB current includes built-in main dialer current, and since main dialer is inactive when 5140DLM is active, 5140DLM imposes only 15mA added current on power supply.

- 8) Enter the calculated combined currents then add to total PCB current.

TOTAL POWER SUPPLY LOAD	Total Current	
	Standby	Alarm
Combined aux. power, bell and polling loop total		
Total PCB current		
Total power supply load		

- 9) Using the total calculated power supply load (step 8), calculate the battery capacity required for the installation.

#### BATTERY CAPACITY CALCULATION WORKSHEET

(For 24 hour standby followed by 5 minute fire or 15 minute fire/burglary alarm)

Capacity	Formula	Calc Value
Standby Capacity	total standby load X 24 hours X 1.1 contingency factor (use total standby load from previous worksheet)	
Alarm Capacity	total alarm load X 0.083 hours (5 minutes) 0.250 hours (15 minutes) (use total alarm load from previous worksheet)	
Total Capacity	Add standby and alarm capacities	

- 10) Using the battery capacity from step 9, select the appropriate battery.

#### BATTERY SELECTION TABLE

(The following batteries will fit inside the 5140XM cabinet)

12 AH	Yuasa NP12-12
14 AH	Yuasa NP7-12 (connect 2 in parallel)
17.2 AH	Yuasa NPG18-12
24 AH	Yuasa NP12-12 (connect 2 in parallel)
28AH	Yuasa NP7-12 (connect 4 in parallel)
34.4 AH	Yuasa NPG18-12 (connect 2 in parallel)

## V. SYSTEM OPERATION

### SECURITY ACCESS CODES

#### GENERAL INFORMATION

The 5140XM system allows up to 99 4-digit security access codes to be programmed. When programmed, each code is assigned a user ID number and an authority level, which determines the system functions that code can be used to perform. There are seven authority levels as listed in the table below. Aside from the installer, who programs codes at installation time, the system allows master and manager level users to program codes on an as needed basis. These codes are intended for use by those who need limited and/or temporary control over system operation.

A Quick Arm feature can also be programmed (field \*29) which enables the [#] key to be pressed instead of entering the security code when arming the burglary system. The security code must still be entered when disarming the system. Note that open/close reporting of Quick Arm is enabled if User 2 is enabled for open/close reporting, and that Quick Arm reports as user 0.

TABLE OF AUTHORITY LEVELS

Level/Title	Enter Program Mode	Arm/Disarm Burglary System	Silence Alarms, Supv & Trouble	Add/Change Security Codes	Bypass Zones	Activate Test Modes
0-Installer	yes	yes, can disarm only if used to arm	yes	yes, for any level including installer level	yes, burglary zones (and fire zones if enabled)	yes, fire & burglary walk tests, fire drill
1-Master	no	yes	yes	yes, levels 2-6 only	yes, burg zones (and fire zones if enabled)	yes, burg, walk test, fire drill only
2-Manager	no	yes	yes	yes, levels 3-6 only	yes, burg zones only	yes, burg, walk test
3-Operator A	no	yes	yes	no	yes, burglary zones only	no
4-Operator B	no	yes	yes	no	no	no
5-Operator C	no	yes, can disarm only if used to arm	yes	no	no	no
6-Duress	no	yes, sends silent panic report	yes	no	no	no

#### INSTALLERS CODE (USER #1/Authority Level 0)

As shipped from the factory, the installer's code is pre-programmed to 5-1-4-0 and can be changed by the installer to any desired code (field \*00).

The installer's code is intended to be known and used only by the installer and his appointed service representatives. During initial installation, the installer uses this code to program security codes for master, manager and lower level users who will operate the system on a day to day basis (see procedures following). The installer's code is the only code that permits entry into programming mode, where the system's operating parameters can be changed. The installer's code is also the only code which permits fire system walk test activation and can be enabled to permit fire sensor and system zones to be bypassed (field 3\*85). The installer's code can be used to perform all normal system functions except that, for added security, this code can be used to disarm the burglary system only if it was used to arm the system. Note that open/close reporting for the installer is enabled in field \*39.

The system also provides an Installer Code lock-out feature, which prevents the use of the Installer's Code from re-accessing the Programming mode after the initial programming. This feature is activated by pressing \*98 to exit Programming mode. The only way to access Programming mode once this feature is activated, is by powering down the system and powering up again, and then pressing both the \* and # keys at the same time within 30 seconds of power up. If re-access to Programming mode using the Installer's Code is desired after initial programming, then exit Programming mode by pressing \*99.

**To ADD a Master,  
Manager or Operator  
code:**

Enter Installer Code + [8] + new User # + new User's code  
(ex. 5140 + [8] + 02 + 1234)

Console will prompt for Authority level. Enter the desired level number from the table above

Console will then prompt for Open/Close reporting option<sup>†</sup>. Press 0 (NO) or 1 (YES). The console will display the user ID number and associated authority level when the new code has been successfully entered.

**To CHANGE a Master,  
Manager or Operator  
code:**

Enter Installer code + [8] + User number + new code for that user

The system will detect that the user number is already assigned and will prompt if this is a new user. Press 0 (NO). The system will then confirm that the change is allowed based on authorization level. If the user number is the same as the Installer's, the system will prompt for the new code to be reentered. This prevents accidentally changing a high level code.

**To DELETE a Master,  
Manager or Operator  
code:**

Enter Installer code + [8] + User number + Installer code

The system will prompt if this code should be deleted. Press 0 (NO) or 1 (YES). If yes, that user's code will be removed and the authority level and all other information about that user will be deleted. Note that a user can only be deleted by a user with a higher authority level. A user cannot delete himself.

**TO EXIT THE USER CODE ENTRY MODE**, either press [\*] or [#], or don't press any key for 10 seconds.

**To VIEW User  
Authority Level**

Once a user code has been programmed, its associated user ID number and authority level can be viewed by entering that user's code + [\*] + [\*].

User numbers must be entered as 2-digit entries. Single digit user numbers must, therefore, always be preceded by a "0" (example, 03, 04, 05, etc.). Make sure the end user understands this requirement. Temporary codes are entered as 4-digit numbers.

**IMPORTANT!:** Unless Ademco Contact ID reporting is used, only user code #1 - #15 can uniquely report to the central station using the communication formats provided. Users #16 - #99 will report as User #15, if enabled for open/close reporting, for the other reporting formats.

**IMPORTANT!:** During user code entry, normal key depressions at other consoles will be ignored. However, panic key depression will cause an alarm and terminate user entry.

**† OPEN/CLOSE REPORTING NOTE:** When adding a user, the system will only prompt for Open/Close report capability if the user is being added by the Installer. When a Master or Manager adds a new user, the new user's Open/Close reporting enable will be the same as that of the Master or Manager adding the user. If Open/Close reports are required to be selectable by the Master or Manager, the Installer should assign two Master or Manager user codes: one with Open/Close reporting enabled, and one without Open/Close reporting.

**MASTER/MANAGER  
CODES (Authority  
Levels 1/2)**

As shipped from the factory, there are no master or manager codes pre-programmed. The installer must program at least one master code during initial installation.

Generally speaking, the Master Code is intended to be known and used by the building owner. The manager code is intended to be known and used by the building superintendent, the building security officer or the like. These codes allow full control over burglary system operation. They can be used to program lower level codes on an as needed basis, for use by those who need limited and/or temporary control over system operation such as supervisors, employees, cleaning personnel, tenants, etc. To add, change or delete user codes, follow the procedure described in the INSTALLER CODE paragraph, substituting master or manager code for the installer code. Note that a master user can program codes for a manager or lower level user, and cannot change a master level code. A Manager can program codes for an operator or for duress, and cannot change a manager level code..

Master Codes and all lower level codes can be used interchangeably when performing system functions (a system armed with an operator's code can be disarmed with the Master Code), with the exception of the Operator C Code described later in this section.

**OPEN/CLOSE REPORTING:** Note that open/close reporting enables for added users are the same as that of the master or manager adding the new user.

**OPERATOR CODES  
(Authority Levels 3-5)**

Operators can arm and disarm the system to the authority assigned, but cannot add or modify any user. If Operator C is selected, that operator's code cannot be used to disarm the system **unless** the system was armed with that code. This code is usually assigned to persons who may have the need to arm and disarm the system at specific times only.

**OPERATOR LEVELS OF AUTHORITY**

Level	Title	Functions Permitted
3	Operator A	Arm, Disarm, Bypass
4	Operator B	Arm, Disarm
5	Operator C	Arm, Disarm only if armed with same code

**DURESS CODE  
(Authority Level 6)**

The duress code is a means of sending a silent alarm to a central monitoring station if the user is being forced to disarm (or arm) the system under threat. This feature is only useful if the system is connected to a central station using the built-in dialer or a LORRA. Duress has its own unique report when digitally communicated, but is signaled on the same trigger that signals silent panic when communicated via the LORRA. When used, the system will disarm (or arm), but will also send a silent alarm to the central station. There will be no indication at the console that an alarm was sent.

## KEYPAD FUNCTIONS

### GENERAL INFORMATION

Note that if QUICK ARM is enabled (field \*29), the [#] key can be pressed instead of entering the security code, for any of the arming procedures (Away, Stay, Instant, Maximum, etc.).

The keypad allows the user to enter commands to silence/reset alarms, to arm and disarm the burglary portion of the system, and to perform other system functions, such as bypassing zones, view messages from the central station and display zone descriptors. Zone and system conditions (alarm, fire supervisory, trouble, bypass) are displayed in the Display Window.

When an alarm occurs, console sounding and external sounding will occur, and the zone(s) in alarm will be displayed on the console. Pressing any key will silence the console sounder for 10 seconds. Entering any security code will disarm the burglary system (if it was armed) and will silence both console and external sounders. When a fire alarm is silenced, consoles will display the message FIRE BELLS SILENCED to indicate that a fire alarm condition may still be present. Any zones that were in an alarm condition will be displayed (memory of alarm). To clear this display and to reset 2-wire devices such as glass break and smoke detectors, simply reenter the security code and press the OFF key. Note that the display will clear only if the zone alarm condition is no longer present.

The consoles also feature chime annunciation, and 3 panic key pairs (for silent, audible, fire or personal emergency alarms) which can notify the central station of an alarm condition, if that service is connected.

### ARMING FUNCTIONS

The following is a brief list of system commands. For detailed information concerning system functions, refer to the User's Manual.

**Disarmed Not Ready** Before arming, the system must be in the READY condition (all zones must be intact). If the "NOT READY" message appears, press the READY [\*] key to display faulted zones.

**Arming Away** Enter code + AWAY [2].

**Arming Stay** Enter code + STAY [3].

**Arming Instant** Enter code + INSTANT [7].

**Arming Maximum** Enter code + MAXIMUM [4].

**Disarming** Enter code + OFF [1].

**Bypassing Zones** Enter code + BYPASS [6] + zone number. To automatically bypass all faulted zones, use "Quick Bypass" method: Enter code + BYPASS + [#].

**Chime Mode** Enter code + CHIME [9]. To turn chime mode off, enter code + CHIME again.

**VIEWING CAPABILITIES OF A USER**

Enter a security code + [\*] + [\*] to view the user ID number and the authority level for that code. These items will typically be displayed as follows:

Part. 1 WHSE  
User 01 Auth.=1.

The user's Open/Close report capability is shown by the dot following the authority level. If Open/Close is not enabled for a user, the dot will not appear.

**VIEWING DOWNLOADED MESSAGES**

Users may occasionally receive messages on the console display from their installation company. When this occurs, the console will display "Message. Press 0 for 5 secs.". Instruct the user to press and hold the 0 key to display the central station's message. Note that the system must be in the READY state to view these messages.

**USING THE BUILT-IN USER'S GUIDE**

An abbreviated User's Manual is stored in the system's memory, and can be particularly useful to the end user if the printed User's Manual is not conveniently accessible when the user needs to perform a seldom used and unfamiliar system procedure. The Built-in User's Guide is displayed by simply pressing any of the function keys (e.g., OFF, AWAY, STAY, MAXIMUM, BYPASS, INSTANT, CODE, TEST, READY, #, and CHIME) for approximately 5 seconds and then releasing it. Abbreviated instructions relative to the key that has been pressed will then be displayed (2 lines of text are displayed at a time). This function is available when the system is in the armed or the disarmed state.

**DISPLAYING DESCRIPTORS**

The Alpha Consoles can display all programmed descriptors, which is useful to the installer when checking entries, and can be helpful to the user when there is a need to identify zones. To display descriptors, press and hold the READY key until the built-in instructions for that key appear, then release the key. The zone descriptors will appear one at a time, for about 2-3 seconds each. For faster viewing, press the READY key to display the next descriptor in numerical order and so on. When all descriptors have been displayed, the Control will exit display mode. To exit display mode before all descriptors have been displayed, enter the security code and press the OFF key.

**PANIC KEYS**

There are three pairs of keys ([\* + 1], [# + 3], [\* + #]) that, if programmed, can be used to manually initiate alarms and send a report to the central station. Each pair of keys can be individually programmed for 24 Hour Silent, Audible or Auxiliary (Emergency) responses. The panic function is activated when the appropriate pair of keys are pressed at the same time.

The panic functions are identified by the system as follows:

<u>PANIC PAIR</u>	<u>Displayed as Zone</u>
* + 1	95
# + 3	96
* + #	99

These panic keys can also be programmed with an alpha descriptor.

**IMPORTANT:** For the Panic functions to be of practical value, the system must be connected to a central station.

## **FIRE SUPERVISORY AND TROUBLE CONDITIONS**

### **GENERAL INFORMATION**

The word "SUPV" on the console's display accompanied by a rapid beeping, indicates that a fire supervisory condition exists. The word "CHECK" on the Console's display, accompanied by a rapid "beeping" at the Console, indicates that there is a trouble condition in the system. The audible warning sound can be silenced by pressing any key.

### **SUPV & "CHECK" MESSAGES**

- A display of "SUPV" accompanied by a sensor zone number (1-64) and an alpha descriptor (if programmed) indicates that a fire supervisory condition exists on that zone which can compromise the operation of the fire alarm system. Instruct the user to CALL FOR SERVICE immediately.
- A display of "CHECK" accompanied by a sensor zone number (1-64) and an alpha descriptor (if programmed) indicates that a problem exists on that zone. The user should first, determine if the zone(s) displayed are intact and make them so if they are not. The user should then enter a security code and press OFF to clear the display. Instruct the user to CALL FOR SERVICE immediately if the display does not clear.
- A display of the word "CHECK" accompanied by a system zone number (70-99) and an alpha descriptor (if programmed) indicates that a problem exists with the system which can compromise system operation. Instruct the user to CALL FOR SERVICE immediately.

### **OTHER TROUBLE CONDITIONS**

- A display of "COMM. FAILURE" at the Console indicates that a failure occurred in the telephone communication portion of your system. Instruct the user to CALL FOR SERVICE immediately.
- A display of "SYSTEM LO BAT" indicates that a low battery condition exists with the system's backup battery. Instruct the user to CALL FOR SERVICE immediately.

### **POWER FAILURE**

If the POWER indicator is off, and the message "AC LOSS" is displayed, the system is operating on battery backup power only. Instruct the user to CALL FOR SERVICE immediately if AC power cannot be restored.

As shipped, the panel is pre-programmed (field \*19) to send an AC loss report to the central station between 6 and 12 hours after the loss of power. The actual time of transmission within this interval is random so as not to simultaneously flood the central station with reports from many panels installed in the area of power outage. (UL requires this setting for field \*19 for commercial fire installations.)

## SETTING THE REAL-TIME CLOCK

The panel uses the real-time clock to trigger test report transmissions and to time/date stamp events written into the event log. The clock must be set for these features to work properly. The clock can be set from the console using the procedure below or via the downloading software.

**To enter real-time clock mode**, enter installer code + #63. The display will show:

TIME/DATE	-	? ON
12:01 AM		01/01/92

The "?" indicates the current mode. The [6] key changes the mode from DAY to HOUR to MINUTE to MONTH to DATE to YEAR. The [4] key changes the mode in reverse order.

The [3] & [1] keys are used to set the TIME/DATE values. The [3] key moves the TIME/DATE ahead, the [1] key moves the TIME/DATE backward.

**To set the day**, use the [3] or [1] key to change from ? ON to MON to TUE, etc.

**To set the time**, press [6] until the "?" appears in the hours position, then use the [3] or [1] key to set the hour. Press [6] again and use the [3] or [1] key to set the minute. Use the [7] key to set AM or PM.

**To set the date**, press the [6] key until the "?" appears in the month position, then use the [3] or [1] key to set the month. Press the [6] key again and use the [3] or [1] key to set the date. Press the [6] key again and use the [3] or [1] key to set to set the year.

**To exit clock mode**, press either the [8] key or the [\*] key. Exiting with the [8] key will save all changes. Exiting with the [\*] key will exit without changing any of the values (used when viewing the time settings, but no changes are desired).



## EVENT LOGGING PROCEDURES

**IMPORTANT:** In order for time and date stamping to occur, the system's real-time clock must be set. Refer to the **SETTING THE REAL TIME CLOCK** section for details.

### GENERAL INFORMATION

The system has the ability to record various events in a history log (224 event capacity) wherein each event is recorded in one of five categories (alarm, supervisory/check, bypass, open & system), with the time and date of its occurrence (if real-time clock is set). The log may be viewed (Display Mode) on the alpha console, or can be printed (Print Mode) on a serial printer (connected to the system via a 4100SM Serial Module; see TRIGGER OUTPUTS section for connection details).

### EVENT LOG MODE COMMANDS

**Display Mode:** Enter user code + [#] + [6] + [0]

**Print Mode:** Enter user code + [#] + [6] + [1]

**Clear Event Log:** Enter user code + [#] + [6] + [2]

**To EXIT Event Log Mode:** Press [\*] at any time.

### PROGRAMMING

The system can be configured for the following event log activities:

- To either record events but not print them unless commanded to do so, or to automatically print the events as they occur (field 1\*72).
- Specific categories of events to be logged can be selectively enabled (field 1\*70).
- The time stamp can be programmed for either 12 or 24 hour formats (field 1\*71).
- The printer baud rate can be set to either 300 or 1200 baud (field 1\*73).
- Set event log time/date report enable (fields 1\*40 & 1\*41).
- Enable reporting of event log capacity (i.e.. 50% full, 90% full & overflow) programmed in fields 1\*40 & 1\*41.

### EVENT LOGGING DISPLAY & PRINT MODES

After entering either mode, the following will be displayed:

ENTER 0 = RECENT  
1 = COMPLETE

The Event Log holds up to 224 events, and can display print all events in a category (complete), or only those events in a category occurring since the last Clear Event Log command (recent). Note that once the Event Log is full, the oldest event will be erased upon the logging of any new event. Press the desired display mode key, 0 or 1.

For display and printing purposes, events are grouped into five categories as follows. Use the [3] & [1] keys to scroll to the next or previous category screens respectively:

ALARM EVENT LOG  
TYPE CCCUUU

Displays time/date for zones that have either caused an alarm or have been restored.

CHECK EVENT LOG  
TYPE CCCUUU

Displays time/date for zones that have caused a trouble or fire supervisory condition.

BYPASS EVENT LOG  
TYPE CCCUUU

Displays time/date for zones that have been bypassed.

OP/CL EVENT LOG  
TYPE CCCUUU

Displays time, date and user number for each arming and disarming of the system.

SYSTEM EVENT LOG  
TYPE CCCUUU

Displays time/date for system problems, such as AC Loss, communication failure, etc.

ALL EVENT LOG  
TYPE CCCUUU

Displays all categories of events in chronological order, from most recent to oldest.

### SCREEN DEFINITIONS

RECENT	Events since last CLEAR
COMPLETE	Displays all events
TYPE	Type of event (Burg., Fire, etc.)
CCC	Zone (contact) number
UUU	User number

To display the events in a particular category, press [8] at the desired category screen. If in Display Mode, events will appear one at a time from the most recent to the oldest. Press [8] again to display each subsequent event. If in Print Mode, the first press of [8] will cause the printer to print all events in that category, with each event automatically scrolled on the display console. The following is a typical display:

```
P1 01/01 12:02AM
BURGLARY C03
```

Shows burglary alarm occurred in zone 3, at 12:02AM on January 1.

After the last event in the selected category has been displayed, the following will appear for a few seconds:

```
END OF EVENT LOG
TYPE CCC UUU
```

The system will automatically return to the RECENT/COMPLETE selection screen described earlier.

#### **CLEAR EVENT LOG**

To clear the Event Log:

Enter user code + [#] + [6] + [2]

The following will appear:

```
CLEAR EVENT LOG
0=NO 1=YES
```

Press [1] if Event Log is to be cleared from memory. All events in the log will still be displayed if the COMPLETE option is selected. Only those events occurring from the time of the CLEAR command will be displayed if RECENT display option is selected. Press [0] if event log is **not** to be cleared at this time.

If [1] is pressed, the following will appear:

```
ARE YOU SURE?
0=NO 1=YES
```

Press [1] if it is desired to clear the event log. Press [0] if event log is not to be cleared.

## VI. SYSTEM COMMUNICATION

### SPLIT/DUAL REPORTING

Dual reporting (\*51) sends all reports to both primary and secondary phone numbers. Split reporting allows reports to be divided between the phone numbers according to the field's (1\*34) selections. Split/Dual reporting can be selected by enabling dual reporting and enabling one of the split reporting options in field 1\*34. If option [1] is selected, all alarms, alarm restores and cancel reports will go to both phone numbers, while all other reports will go to the secondary phone number only. If [2] is selected, open/close and test messages will go to both phone numbers, while all other reports will go to the primary phone number only. Following are the Split/Dual Reporting options:

REPORTING FORMAT	FIELD NUMBERS	
	*51	1*34
DUAL	1	0
SPLIT	0	1 or 2
SPLIT/DUAL	1	1 or 2

### ADEMCO LOW SPEED

ADEMCO LOW SPEED is a pulsed format which responds to a 1400 Hz handshake and kiss-off, and transmits data with 1900Hz pulse tones @ 10 pulses per second (pps). A typical message consists of two rounds which must be verified by the receiver. A complete standard report consists of either a 3 or 4-digit account number followed by a 1-digit alarm code. Though 2 rounds are sent, only the valid report is displayed.

In expanded reporting, two messages are sent, two rounds per message, the first being the account number and alarm code, the second being the zone ID code to which the alarm was assigned. A complete expanded report consists of a 3 or 4-digit account number followed by a 1-digit alarm code, then the alarm code is repeated, followed by the channel number.

EX. Standard: CCCC E where: CCCC = account number  
 Expanded: CCCC E E = event code  
 EEEE Z Z = zone ID code

### SESCO/RADIONICS

Standard and expanded reporting in the SESCO/RADIONICS format is virtually the same as ADEMCO Low Speed except for the following:

1. The handshake and kiss-off frequency is 2300 Hz.
2. The data is transmitted with 1800 Hz pulse tones.
3. The rate of transmission is 20 pps.

### 4+2 REPORTING

A 4+2 report consists of a 4-digit account number and a 2-digit alarm code, or event code. 4+2 reports can be accomplished either in ADEMCO Low Speed (10 pps), or SESCO/RADIONICS (20 pps) format.

In 4+2 reporting a unique 2-digit code for each zone is reported. A 4-digit account number followed by a 2-digit code is sent, where the first digit is the actual event, such as in ALARM, RESTORE, or TROUBLE, etc., and the second digit of the code represents the "zone" where the event occurred. (but not necessarily the actual zone number). Each code in itself is unique to a specific zone. If desired, the actual zone number can be reported by entering the corresponding 2-digit zone number (ex. zone 1= [0] [1]; zone 63= [6] [3]). A report might appear as:

1 2 3 4 5 9 ("5 9" might be a unique "TROUBLE RESTORE, ZONE 25).

### 4+2 EXPRESS

ADEMCO's new Express format provides the same information as the 4+2 format, but with three differences:

1. The data is transmitted in DTMF (Dual Tone Multi-Frequency, known as "TouchTone", at the rate of 10 characters per second). This greatly decreases the time it takes a report to go through to central station. An average 4+2 Low Speed report might take as long as 20 seconds to complete its report, but 4+2 Express takes under 3 secs.
2. Two message rounds are eliminated by the use of a checksum digit. Instead of the communicator sending 2 rounds per report, it sends only 1 round with a checksum digit at the end. Doing this also helps in decreasing the time it takes for a report to be sent.
3. The handshake frequency is 1400 Hz followed by 2300 Hz, and the kiss-off frequency is 1400 Hz.

## **ADEMCO HIGH SPEED REPORTING**

ADEMCO's High Speed format transmits data in DTMF at a rate of 10 characters per second. The handshake frequency is 1400 Hz followed by 2300 Hz, and the kissoff frequency is 1400 Hz. The message contains 13 digits as follows: A 4-digit account number + eight channels of zone information (1-8 or duress plus 9-15) + one status channel, which identifies the type of events being reported in the eight zone locations. A typical High Speed report will be kissed off in under 5 seconds.

Channels 1 through 8 could have one of the following conditions:

- 1 = NEW EVENT
- 2 = OPENING (Status Channel Always = 2)\*
- 3 = RESTORE
- 4 = CLOSING (Status Channel Always = 4)\*
- 5 = NORMAL, NO EVENT TO REPORT
- 6 = PREVIOUSLY REPORTED, NOT YET RESTORED

\* NOTE: Channel 1 will contain the user ID 1-9, A-F if Open/Close reporting is enabled.

The status channel might have one of the following conditions:

- 1 = DURESS (For Duress Plus Channels 9-15 Only)
- 2 = OPENING
- 3 = BYPASS (For Channels 1-8 Only)
- 4 = CLOSING
- 5 = SUPERVISORY/TROUBLE (For Channels 1-8 Only)
- 6 = SYSTEM STATUS:
  - AC LOSS in Channel 1
  - LOW BATTERY in Channel 2
  - PROGRAM TAMPER, BELL 1 TRB, BELL 2 TRB in Channel 3
  - POWER ON RESET in Channel 4
  - DIALER 1 TRB, DIALER 2 TRB in channel 6
  - BELL1, BELL 2, DIALER 1 AND DIALER 2 BYPASS in channel 7
  - WALK TEST START, END in channel 8
- 7 = NORMAL ALARM STATUS (Chnls 1-8 Only)
- 9 = TEST REPORT

A typical high speed report may look as follows:

1234 5115 5555 7 (Acct #1234 with alarms on channels 2 and 3)

### **LIMITATIONS**

1. When using Ademco high speed, remember there are only 15 channels available, plus a duress channel. If more than 15 zones are being used, they will have to share channels.
2. With Ademco High Speed reporting, channels 9-15 cannot report troubles or bypasses. Use these channels for zones that will not report these conditions.
3. Only user numbers 1-15 can be uniquely reported with open/close reports in Ademco High Speed.

## **CONTACT ID REPORTING**

This is the only format that can identify all 64 protection zones by their unique zone (Contact) ID numbers, and provides a 1-digit event qualifier and 3-digit, specifically defined event code which quickly identifies the condition being reported.

Contact ID reports in DTMF (Dual Tone Multi-Frequency @ 10 characters per second) and responds to a 1400 Hz followed by 2300 Hz handshake, and a 1400 Hz kissoff. This format also uses checksum instead of two message verification. A complete report takes under 3 seconds.

Contact ID Reporting takes the format: CCCC Q EEE GG ZZZ where:

- CCCC = Customer (subscriber) number.
- Q = Event qualifier, where: E=new event (1) and R= restore (3)
- EEE = Event code (3 hexadecimal digits), defined in the table on the next page.
- GG = May be 00 or 01.
- ZZZ = Zone/contact ID number reporting the alarm (001-099), or user number (001-099) for open/close reports. System status messages (AC Loss, Walk Test, etc.) contain zeroes in the ZZZ location.

### TABLE OF CONTACT ID EVENT CODES

Code	Definition
110	Fire Alarm
111	Smoke Alarm*
113	Water Flow Alarm
121	Duress
122	Silent Panic
123	Audible Panic
131	Perimeter Burglary
132	Interior Burglary
133	24 Hour Burglary
134	Entry/Exit Burglary
135	Day/Night Burglary
142	Polling Loop Short Alarm
150	24 Hour Auxiliary
200	Fire Supervisory
301	AC Loss
302	Low System Battery
305	System Reset
306	Program Tamper
309	Battery Test Fail
310	Ground Fault
321	Bell 1 Trouble
322	Bell 2 Trouble
332	Poll Loop Short-Trouble
351	Main Dialer Trouble
352	Backup Dialer Trouble

Code	Definition
373	Fire Loop Trouble
380	Trouble (global)
382	Loss of RPM Supervision
383	RPM Sensor Tamper
401	O/C By User
403	Power-Up Armed
406	Cancel by User
407	Remote Arm/Disarm (Download)
408	Quick Arm
409	Keyswitch O/C
411	Call back Requested
441	Armed STAY
521	Bell 1 Bypass
522	Bell 2 Bypass
524	Auxiliary Relay Bypass
551	Main/Backup Dialer Bypass
570	Bypass
602	Communicator Test
607	Fire and Burglary Walk Test
621	Event Log Reset
622	Event Log 50% Full
623	Event Log 90% Full
624	Event Log Overflow
625	Time/Date Reset

\*This report is transmitted whenever an alarm is detected on a zone programmed for Fire Alarm w/Verification.

**ADVISORY:** Ademco's new Contact ID reporting is capable of uniquely reporting all 64 zones of information, as well as openings and closings for all 128 users, to central stations equipped with the Ademco 685 receiver using software level 4.5 or higher. 685 software levels below 4.5 cannot support Contact ID reporting. For information regarding updating the 685 receiver, contact Ademco's Technical Support group at 1-800-645-7492 (NY) or 1-800-458-9469 (CA).

### 5140XM COMMUNICATION PROGRAMMING GUIDE

Field #	Low Speed	Contact ID	High Speed	Express
*46, *48	Choose transmission speed and frequency	No effect	No effect	No effect
*52, *53	Send as either 4+2 or exp.	No effect	No effect	No effect
*79, *80, 3*50	Enables alarm restores	Enables alarm restores	Enables alarm restores	Enables alarm restores
*49	Add checksum digit	No effect	Add checksum digit	No effect
*81, *82, 3*51, 3*52, 1*40, 1*41	Define codes and selects 4+1 or 4+2	1st digit enables report if it is non-zero	1st digit enables report if it is non-zero	Define codes and selects 4+1 or 4+2
*54, *56, *59, *61, *64, *66, *69, *71, *76, 3*40	Defines alarm/fire supervisory event code	Enables reports	Assigns reporting chnl for all reports from this zone. Enables alarm report	Defines alarm event code
*55, *57, *60, *62, *65, *67, *70, *72, *77, 3*41	Defines code and selects 4+1 or 4+2	No effect	No effect	Defines code and selects 4+1 or 4+2
*58, *63, *68, *73, *78, 3*42	Enables report and selects code. Note: No restores if event not sent	Enables report	Enables report Note: Alarm channel must be programmed. (01-15)	Enables report and selects 1st digit of the 2-digit event code. NOTE: No restores if event not sent.
*50	Sescoa/Radionics; Selects fixed digit time instead of fixed interdigit.	No effect	No effect	No effect
NOTES	Note: Low Speed will not send 3+2 messages. Zone ID digit is suppressed.	Note: If Contact ID is desired, it must be used on both primary & secondary phone #s.	If High Speed is used for secondary, it <b>must</b> be used for primary. If used on primary, any other format can be used on secondary.	

# VII. PROGRAMMING THE SYSTEM

## GENERAL PROGRAMMING PROCEDURES

### GENERAL INFORMATION

The system is shipped with a set of pre-programmed values that are designed to meet the needs of many installations. These can be changed by the installer to suit specific needs if desired. In addition, four sets of pre-programmed communication default values can also be loaded by the installer, each set designed for a specific communication format. These too can be changed to suit the needs of a particular installation.

Changes to these pre-programmed values can be programmed directly from the console or from an IBM compatible computer terminal either remotely (using a HAYES 1200 SMARTMODEM) or at the job site (using the 4100SM Serial Module). NOTE: Remote downloading is not a UL Listed feature. Both methods use the 4130PC Downloading software (be sure that the software version used includes a 5140XM menu selection). See the DOWNLOADING section for more information.

For alpha consoles, English Language descriptions of the zones and a custom installer message (which appears when the system is ready to arm) can be programmed using the built-in vocabulary of words (see #93 MENU MODE, ALPHA PROGRAMMING paragraphs later in this section).

### USER-FRIENDLY ZONE, DEVICE & ALPHA PROGRAMMING (#93 Menu Mode)

To help set up the system quickly and accurately, Ademco has provided a tremendous aid to the programming process. Instead of the traditional method of programming all the fields associated with zones, you may now logically program a zone for all its characteristics as prompted by the 5140XM (refer to the #93 MENU MODE, ZONE PROGRAMMING section for details). This ensures that a zone response type has been assigned to each zone.

This user-friendly scheme for programming eliminates the possibility of you forgetting to enter a field properly or simply forgetting it altogether! The system can now be programmed the way you approach your installations, by zones!

This User Friendly Menu Mode can also be used for programming remote console characteristics, and for entering alpha descriptors.

### COMMUNICATION DEFAULT PROGRAMMING

There are five sets of pre-programmed defaults available (one standard, plus four different communication defaults). Any one of these can be loaded into the system's memory. Refer to the COMMUNICATION PROGRAMMING section for instructions.

### PROGRAMMING STEPS

#### 1. Enter Programming mode

Programming mode can be entered in one of two ways.

- 1) By depressing the [\*] and [#] keys at the same time within 30 seconds after power is applied to the Control.
- 2) By keying the installer code, followed by depression of CODE + 0 + 0 keys. The factory installer code can be changed once in the program mode.

Immediately following entry into the program mode, the following will be displayed:

Program Mode  
\* Fill # View - 00

Following the above display, the system is ready to be programmed for the communication format parameters, or accept data entries.

#### 2. Set Standard and/or Communication Defaults

Refer to the PROGRAMMING COMMUNICATION DEFAULTS section for further instructions if one of the four communication default programming sets is used.

#### 3. Program data fields for system parameters

Program all system programming fields, including phone numbers and account numbers, as well as any other programming fields required to customize the system to the needs of the installation. Refer to the PROGRAMMING DATA FIELDS section for specific commands and instructions.

#### 4. Use #93 Menu Mode for zone programming

Refer to the ZONE PROGRAMMING section to program zone response types.

**PROGRAMMING STEPS  
(cont.)**

5. **Use #93 Menu Mode for device programming**  
Refer to the DEVICE PROGRAMMING section to assign console ID numbers, and to selectively suppress certain console sounding.
6. **Use #93 Menu Mode for programming alpha descriptors**  
Refer to the ALPHA PROGRAMMING section to enter zone descriptors and a custom installer's message.
7. **Exit Programming Mode**  
Exit programming mode by pressing either \*98 or \*99. A second entry of \*99 is required if the exit is being done from fields 1\*00 to 1\*99, and a third entry of \*99 is required if exit is being done from fields 3\*00 and above. To prevent re-access to Programming mode using the Installer's code, use \*98. The only way to re-access Programming mode is by depressing both the [\*] and [#] keys at the same time within 30 seconds of power up. Exiting by using \*99 always allows reentry into Programming mode using the Installer's code. Either way of exiting will allow access via downloading.

# COMMUNICATION PROGRAMMING

## GENERAL INFORMATION

To help expedite the installation, Ademco has incorporated 4 different communication defaults in the Control (Low Speed, Ademco Express, Ademco High Speed & Ademco's new Contact ID). These defaults automatically program industry-standard code assignments for zones, keypad panics, non-alarm and supervisory conditions, and can be loaded at any time without affecting non-communication program fields. Using these defaults saves programming time! After loading one of the communication defaults, you only need to wire the devices to their appropriate zones, and program the following:

- Central station phone number(s), fields \*33 & \*34
- Subscriber's account number(s), fields \*32 & \*90
- Zone type responses, fields \*02-\*05, 1\*01-1\*05 & 3\*10
- Bell 1, Bell 2 and Aux Relay assignments, fields 3\*15, 3\*61, 3\*70-3\*81.
- Delays, timeouts, and miscellaneous control options.

The system is then operational.

## LOADING COMMUNICATION DEFAULTS

**NOTE:** Default communication commands are in second set of programming fields (fields 1\*80, 1\*81, 1\*82 & 1\*83).

Once the Programming mode is entered, clear the system's memory by pressing \*97. This ensures all program fields are set to their factory set, pre-programmed values. If desired, load one of the communication default programming sets by first changing to the 1\*xx set of fields (press \*94), then entering one of the following field numbers:

TABLE OF DEFAULT PROGRAMMING COMMANDS

PRESS	TO LOAD THIS DEFAULT PROGRAM SET
*97	Loads standard default values for the panel
*80	Low Speed communication defaults
*81	Ademco Express communication defaults
*82	Ademco High Speed communication defaults
*83	Contact ID communication defaults

The program fields that are affected by loading one of the communication defaults are fields \*45 - \*82, 1\*40, 1\*41 3\*40-3\*42, 3\*50-3\*52. Default values for each communication default are listed at the end of this manual. For detailed information about reporting formats, see the SYSTEM COMMUNICATION section. After loading one of the default sets, proceed to program the system data fields as described in the PROGRAMMING DATA FIELDS section.

## EASY-TO-PROGRAM COMMUNICATION FIELDS

The programming scheme eliminates the need to program zones to channels, and then channels to codes. If programming communication fields manually, simply enter whatever code (3+1, 4+1, 4+2 or Ademco Express) is to be sent for each zone (including panics, non-alarm codes and supervisory codes). NOTE: Enter "10" to transmit an "A", which appears as "0" at the receiver.

All zones are separated into groups of 8, with common restore, trouble and bypass codes for every 2 groups (16 zones). There are 2 double-digit entries for each code. For 3+1, 4+1, 4+2 and Ademco Express, the first entry is the alarm code for a standard report. The second entry is the ID digit for an expanded 3+1 or 4+1 report, or for a 4+2 or Ademco Express report. If the second digit is 0, only 3+1 or 4+1 (or 4+1 express) non-expanded messages will be sent. If only three digits are entered in the account number field, the ID or second digits are ignored, if entered. For Ademco High Speed format, the first digit entry is the channel assignment for that zone, and the second digit is ignored, if entered. For Contact ID reporting, the first digit entry (any non zero entry) enables reporting for that zone, and the second digit is ignored.

NOTE: Restoral reports for an event **will not** be sent if the event itself is not enabled, even if a restore code is programmed for that event.



**SUMMARY OF  
DEFAULT  
CONSEQUENCES**

**Low Speed (\*94\*80)**

Loading this default does the following:

- Selects low speed, standard format with no checksum, for both phone numbers.
- Assigns the following report codes:
  - 03 for zones 3-47, 56-61, 64
  - 01 for zones 1, 2 & 48-55 (fire zones)
  - 02 for zones 62,63 (panic trans), & 95, 96, 99 (keypad panics)
  - 09 for all alarm restores
- Enables all zone type restores.

**ADEMCO Express (\*94\*81)**

Loading this default does the following:

- Selects Ademco express reporting format, with checksum, for both phone numbers.
- Report codes for sensor zones 1-64 and system zones 70-99 are sent as their respective zone ID numbers (01-99), Duress is sent as "DD". Alarm restore is "E" + 2nd digit.
- Enables all zone type restores.

**ADEMCO High Speed (\*94\*82)**

Loading this default does the following:

- Selects Ademco High Speed format, with no checksum, for both phone numbers.
- Reporting is assigned to the following channels:
  - Channel 1 for zones 1,2 & 48-55 (Fire zones)
  - Channel 2 for zones 3-8
  - Channel 3 for zones 9-16
  - Channel 4 for zones 17-31
  - Channel 5 for zones 32-47
  - Channel 6 for zones 56-61 & 64
  - Channel 9 for zones 62 & 63
  - Channel 7 for system zones 70-77 & 97
  - Channel 8 not used
- Channels 10, 11 & 12 for keypad panics 95, 96 & 99 respectively
- Enables all zone type restores.
- Enables Duress to be sent.

**ADEMCO's Contact ID (\*94\*83)**

Loading this default does the following:

- Selects Contact ID format for both phone numbers.
- Reporting is enabled for all zones.
- Enables all zone type restores.
- Refer to the SYSTEM COMMUNICATION section for event code definitions.

**PROGRAMMING DATA FIELDS**

The programming fields are grouped into three sets (or "pages"), as represented in the diagram below. The first set is accessed as soon as programming mode is entered. To access the other sets of fields (indicated on the programming form by a "1" or "3" in front of the 2-digit field address), press \*94. Note that the alpha consoles display the words ALT PROGRAM MODE to indicate the higher set of fields. To return to the previous set of fields, press \*99. When programming data fields, the fields listed in the table in the ZONE PROGRAMMING section can be skipped, since they can be programmed using the user-friendly ZONE PROGRAMMING Menu Mode.

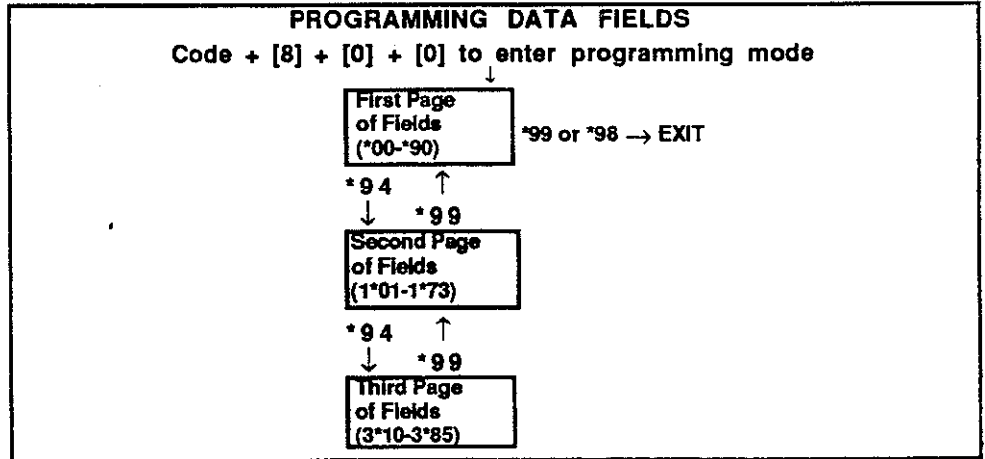

To program specific data fields, press [\*] plus the 2-digit field address, then make the required entry. The console will beep when a field has been completely programmed and will automatically display the next field in sequence. If the number of digits that you enter in the data field is less than the maximum permitted (ex. phone number), the console displays the last entry and waits. To proceed, the next data field to be programmed must be entered manually (ex. press \*05).

To view the contents of a data field, press [#] plus the 2-digit field address. The field's entries will be displayed, but no changes can be made.

**In case of errors:** If an address is improperly entered, the console will display FC. If a program entry is improperly entered (for example, a larger number than that which is permitted), the console display will go blank. In either case, simply re-enter the correct number.

KEY COMMANDS	
*94	Next set of fields
*99	Previous set of fields or exit programming mode
#93	Enter Zone/Alpha/Device Programming mode
*98	Exit programming mode with installer lock-out

## #93 USER FRIENDLY MENU MODE

**GENERAL INFORMATION** After programming all system related programming fields in the usual way, press #93 to display the first choice of the three menu driven programming functions, which are: Zone Programming (for programming zone types), Alpha Programming (for programming alpha descriptors) & Device Programming (for programming console characteristics). Press 0 (NO) or 1 (YES) in response to the selection. Pressing 0 will display the next choice in sequence. Refer to the ZONE PROGRAMMING section for instructions for programming zone characteristics, the DEVICE PROGRAMMING section for instructions for programming remote consoles, and the ALPHA PROGRAMMING section for programming alpha descriptors. The list of commands used while in the menu mode is shown at the right.

### ZONE PROGRAMMING

The following fields can be programmed by using the ZONE PROGRAMMING Menu Mode:

#### ZONE PROGRAMMING FIELDS

*02-*05	Zone response types for zones 1-27, 95-99
1*01-1*05	Zone response types for zones 28-64
3*10	Zone response types for system zones 70-75

1. Enter Programming mode, then press #93 to display "ZONE PROG?". Press 1 to enter ZONE PROGRAMMING mode.
2. Enter the zone number to be programmed (01-64, 70-75, 95, 96, 97 or 99). Press [\*] to accept entry.
3. Enter the zone response type for that zone (01-19). The screen will automatically display the zone type for the number entered. Press [\*] to accept entry. If a different zone response type is desired, enter a different number and press [\*].
4. The display will repeat with the zone number question for programming the other zones in the system. Enter 00 to exit back to normal programming mode.

#### #93 MENU MODE KEY COMMANDS

#93	Enters Menu mode
[*]	Serves as ENTER key. Press to have console accept entry.
[#]	Skips to next screen display without changing existing entries.
0	Press to answer NO
1	Press to answer YES
01-09	All entries are 2-digit entries
00	Escapes from menu mode, back into field programming mode.

### DEVICE PROGRAMMING

NOTE 1: Console ID number 00 is permanently enabled and set for no sounder suppression. This cannot be changed.

NOTE 2: The panel is factory pre-programmed with all console ID numbers (01-30) enabled and set for no sounder suppression. Use the DEVICE PROGRAMMING mode at initial installation only if it is desired to change the sounder options for one or more consoles

1. Enter Programming mode, then press #93 to display "ZONE PROG?". Press 0 (NO) to display "ALPHA PROG?". Press 0 again to display "DEVICE PROG?". Press 1 to enter DEVICE PROGRAMMING mode.
2. Enter the 2-digit console ID number as set by its DIP switches (01-30). Press [\*] to accept entry.
3. Enter 01 and press [\*]. Enter 01 again and press [\*].
4. Enter a number 00-03 for the console sounding suppression options desired for this console as follows:  
Enter 00 for no suppression.  
Enter 01 to suppress arm/disarm & entry/exit beeps.  
Enter 02 to suppress chime mode beeps only.  
Enter 03 to suppress arm/disarm, entry/exit and chime mode beeps.  
The screen will display the next console number to be programmed.
5. Press 00 to exit Menu Mode.

## ALPHA PROGRAMMING

### Assigning Zone Descriptors

A user friendly English language description/location of all protection zones and system zones can be programmed into the system. Each description can be composed of a combination of words (up to a maximum of 3) that are selected from a vocabulary of approximately 220 words stored in memory, and any word can have an "s" or " 's " added to it. In addition, up to 20 installer-defined words can be added to those already in memory. Thus, when an alarm or trouble occurs in a zone, an appropriate description for the location of that zone will be displayed at the console. An installer's message can also be programmed which will be displayed when the system is "Ready" (ex. THE PETERSON's).

To program alpha descriptors, enter Programming mode, then press #93 to display "ZONE PROG?". Press 0 (NO) to display "ALPHA PROG?". Press 1 to enter ALPHA PROGRAMMING mode. There are 5 sub-menu selections that will be displayed one at a time. Press 1 to select the mode desired. Press 0 to display the next mode available. The alpha sub menu selections are:

ZONE DESCRIP.?	for entering zone descriptors.
DEFAULT SCREEN?	for creating custom message; shows when system ready.
CUSTOM WORD?	for creating custom words for use in descriptors.
PART DESCRIP?	Not Used
EXIT EDIT MODE?	Press 1 to exit #93 Menu Mode.

### Entering Zone Descriptors

1. Select ZONE DESCRIP mode.

The console keys perform the following functions:

- [3] Scrolls both alphabet and actual words in ascending alphabetical order.
- [1] Scrolls both alphabet and actual words in descending alphabetical order.
- [2] Adds or removes an "s" or " 's " to a vocabulary word.
- [6] Toggles between alphabet and actual word list; used to accept entries.
- [8] Saves the zone description in the system's memory.
- [#] # plus zone number will display the description for that zone.

2. Key \*01 to begin entering the description for zone 1, (key \*02 for zone 2, \*03 for zone 3 etc.). The following will be displayed: \* ZN 01 A

Note that the first letter of the alphabet appears after the zone number, and that the zone number is automatically included with the description.

3. Select the first letter of the desired description (note that "A" is already displayed). Use key [3] to advance through the alphabet and key [1] to go backward. For example, assume the desired description for zone 1 is BACK DOOR. Press key [3] repeatedly (or hold down the key) until "B" appears, then press key [6]. to display the first available word beginning with B. Repeatedly press key [3] to advance through the available words until the word BACK is displayed. Press key [1] to move backward through the word list.

To add an "s" or " 's ", press the [2] key. The first depression adds an "s", the second depression adds an " 's ", the third depression displays no character (to erase the character), the fourth depression adds an "s", etc.

To accept the word, press the [6] key, which toggles back to alphabet list.

4. For selection of the next word (DOOR), repeat step 3, but press key [3] until the desired first letter of the next word appears (in this example, "D"). Then press key [6] to display the first available word beginning with "D". Press key [3] repeatedly until the desired word (DOOR) appears. To accept the word, press the [6] key, which again toggles back to alphabet list.
5. When all desired words have been entered, press key [8] to store the description in memory.
6. To review the zone descriptions, key [#] plus zone number (e.g., #01). To edit zone descriptions, key [\*] plus zone number (e.g., \*01)
7. To exit the zone description mode, key 00.

**NOTE:** Alpha descriptor entry can be entered locally at the console or remotely using a 4130PC Downloader.

### Adding Custom Words

Up to 20 installer-defined words can be added to the built-in vocabulary. Each of the 20 "words" can actually consist of several words, but bear in mind that a maximum of 10 characters can be used for each word string.

1. Select CUSTOM WORD mode. The keys perform the following functions:
  - [3] Advances through alphabet in ascending order.
  - [1] Advances through alphabet in descending order.
  - [6] Selects desired letter; moves the cursor 1 space right.
  - [4] Moves the cursor one space to the left.
  - [7] Inserts a space at the cursor location, erasing any character at that location.
  - [8] Saves the new word in the system's memory.
  - [\*] Returns to description entry mode.
4. Key the number of the custom word or word string to be created (01-20). For example, if you are creating the first word (or word string), enter 01; when creating the second word, enter 02, and so on. A cursor will now appear at the beginning of the second line.
5. Use the [3] key to advance through the alphabet (numbers, symbols and special characters are included). Use the [1] key to move back through the alphabet.  
**IMPORTANT:** Custom words must begin with an alphabetic character. If numbers or symbols are used as the first character, the word will not be saved.
6. When you have reached the desired character, press the [6] key to select it. The cursor will then move to the right, in position for the next character.
7. Repeat steps 5 and 6 to create the desired word (or words). Note that the [4] key can be used to move the cursor to the left if necessary, and that key [7] can be used to enter a blank (or to erase an existing character). Each word or word string cannot exceed 10 characters.
8. Press the [8] key to save the custom word(s) and return to the \* ED ?? display. The custom word (or string of words) will be automatically added to the built-in vocabulary at the end of the group of words beginning with the same letter.
9. Repeat steps 4 through 8 to create up to 19 additional custom words (or word strings).
10. Press the [\*] key to return to the \*ZN ?? display, and follow the zone description entry procedure to assign the new words to a zone description.
11. Key 00 to exit the zone description programming mode.

### Creating A Custom Message Display (Installer's Message)

Normally, when the system is in the disarmed state, the following display is present on the Console.

```
****DISARMED**** READY TO ARM
```

Part or all of the above message can be modified to create a custom installer message. For example, \*\*\*\*DISARMED\*\*\*\* on the first line or READY TO ARM on the second line could be replaced by the installation company name or phone number for service. Note that there are only 16 character spaces on each of the two lines. To create a custom display message, proceed as follows:

1. Select default screen mode. Enter 1.  
The following will appear:

```
****DISARMED****  
READY TO ARM
```

A cursor will be present at the extreme left of the first line (over the first "star"). The [6] key is used to move the cursor to the right and the [4] key to move the cursor to the left. Key [7] may be used to insert spaces or erase existing characters.
2. For example, to replace READY TO ARM with the message SERVICE:424-0177, proceed as follows:  
Press the [6] key to move the cursor to the right, and continue until the cursor is positioned over the first location on the second line.  
Press the [3] key to advance through the alphabet to the first desired character (in this case, "S"). Use the [1] key to go backward, when necessary. When the desired character is reached, press [6]. The cursor will then move to the next position, ready for entry of the next character (in this example, "E"). When the cursor reaches a position over an existing character, pressing the [3] or [1] key will advance or back up from that character in the alphabet. Proceed in this manner until all characters in the message have been entered.
3. To store this new display message in memory, press the [8] key.
4. Press the [\*] key to return to the \* ZN ?? display. To confirm that the new message has been stored in memory, press 00 and then press 00 again. The new message should be displayed.
5. Key 0 to exit the descriptor/programming mode.

VOCABULARY OF WORDS STORED IN MEMORY\*

AIR	CLOSED	FIRE	LORRA	RADIO	TELEPHONE
ALARM	COIN	FLOOR	LOW	REAR	TELLER
ALCOVE	COLD	FLOW	LOWER	RECREATION	TEMPERATURE
ALLEY	COATROOM	FOIL		REFRIG	THERMOSTAT
AMBUSH	COLLECTION	FOYER	MACHINE	REFRIGERATION	TOOL
ANTENNA	COMBUSTION	FREEZER	MAGNETIC	RELAY-1	TRANSMITTER
AREA	COMPUTER	FRONT	MAIDS	RF	TRAP
APARTMENT	CONTACT	FUR	MAIN	RIGHT	TRIGGERS
ART		FURNACE	MASTER	ROOM	
ATTIC	DAUGHTERS		MAT	ROOF	ULTRA
AUDIO	DELAYED	GALLERY	MEDICAL		UP
AUX	DEN	GARAGE	MEDICINE	SAFE	UPPER
AUXILIARY	DESK	GAS	MICROWAVE	SCREEN	UPSTAIRS
	DETECTOR	GATE	MONEY	SENSOR	UTILITY
BABY	DIALER-1	GLASS	MONITOR	SERVICE	
BACK	DIALER-2	GROUND	MOTHERS	SHED	VALVE
BAR	DINING	GUEST	MOTION	SHOCK	VAULT
BARN	DISCRIMINATOR	GUN	MOTOR	SHOP	VIBRATION
BASEMENT	DISPLAY		MUD	SHORT	VOLTAGE
BATHROOM	DOCK	HALL		SHOW	
BED	DOOR	HEAT	NORTH	SHOW	WALL
BEDROOM	DORMER	HIGH	NURSERY	SKYLIGHT	WAREHOUSE
BELL	DOWN	HOLDUP		SLIDING	WASH
BELL-1	DOWNSTAIRS	HOUSE	OFFICE	SMOKE	WEST
BELL-2	DRAWER		OIL	SONIC	WINDOW
BLOWER	DRIVEWAY	INFRARED	OPEN	SONS	WINE
BOILER	DRUG	INSIDE	OPENING	SOUTH	WING
BOTTOM	DUCT	INTERIOR	OUTSIDE	SPRINKLER	WORK
BOX		INTRUSION	OVERFLOW	STAMP	
BREAK	EARTH		OVERHEAD	STATION	XMITTER
BUILDING	EAST	JEWELRY		STEREO	
BURNER	ELECTRIC	KITCHEN	PAINTING	STORE	YARD
	EMERGENCY		PANIC	STORAGE	
CABINET	ENTRY	LAUNDRY	PASSIVE	STORY	ZONE
CALL	EQUIPMENT	LEFT	PATIO	STRESS	
CAMERA	EXECUTIVE	LEVEL	PERIMETER	STRIKE	0
CAR	EXIT	LIBRARY	PHONE	SUMP	1ST
CASE	EXTERIOR	LIGHT	PHOTO	SUPERVISED	2ND
CASH		LIQUOR	POINT	SUPERVISION	3RD
CCTV	FACTORY	LIVING	POLICE	SWIMMING	4TH
CEILING	FAILURE	LOADING	POOL	SWITCH	5TH
CELLAR	FAMILY	LOCK	POWER		6TH
CENTRAL	FATHERS	LOOP		TAMPER	7TH
CIRCUIT	FENCE		QUAD	TAPE	8TH
CLIP	FILE			TELCO	9TH

\*Note: This factory-provided vocabulary of words is subject to change.

## VIII. DOWNLOADING PRIMER

(Remote Downloader is not a UL approved feature)

### WHAT IS DOWNLOADING?

Downloading allows the operator to remotely access, program, and control the security system over normal telephone lines. Anything that can be done directly from the keypad can be done remotely, using DOWNLOADING. To Download, the following is required:

**NOTE:**  
Internal modems must have  
4 position DIP switch.  
Modems with 6 position DIP  
switch will not work.

1. An IBM PC, or compatible computer with MS DOS 3.1 or higher, to run the DOWNLOADING program. MS DOS stands for: Microsoft Disk Operating System.
3. A HAYES 1200 SMARTMODEM (external: level 1.2 or higher; internal: level 1.1 or higher). If these levels cannot be found locally, an external modem can be purchased from ADEMCO, or contact HAYES for a free update. *Other brands are not compatible, even if claimed to be 100% compatible.*
4. 4130PC V-LINK® DOWNLOADING software, from ADEMCO. This software is available in both 3-1/2" (4130P3-3) and 5-1/4" diskettes, and includes a complete User's Manual.

### HOW DOES DOWNLOADING WORK?

At the protected premises, the Control panel must be connected to the existing telephone line (refer to the PHONE LINE CONNECTIONS section). No programming of the panel is required before downloading to an initial installation.

To download, do the following:

1. Enter the installer code + [#] + [5]. The panel temporarily enables a ring count of 5 and sets the Download Callback option to "1" (callback not required).
2. Call the panel using the downloader software set to "FIRST COMMUNICATION" mode.
3. The downloader will establish a session with no callback. The panel information can then be downloaded.

In order to remotely access, control, or program the alarm panel, a "link" must be established between the computer and the control panel, as follows:

1. The computer calls up the Control panel. (The phone number for each customer is entered into the customer's account file on the computer).
2. The Control panel "answers" at the pre-programmed ring count and executes a handshake with the computer.
3. The computer sends a request for call-back to the Control, unless call-back is not required.
4. The panel acknowledges the request and hangs up. During the next few seconds, the Control will process the request making sure certain encrypted information, received from the computer, matches its own memory.
5. Upon a successful match, the Control panel will seize the phone line and call the computer back, unless call-back is not required.
6. The computer answers, usually by the second ring, and executes a handshake with the panel.
7. The panel then sends other default information to the computer. If this information matches the computer's information, a successful link is established. This is known as being "ON-LINE".

### ADVISORIES:

1. Alarm and trouble responses and reports are disabled during on-line time. Should an event occur during this time, the response will take place and the report will go through as soon as the remote access sequence is completed. Alarm and trouble conditions are not ignored, they are simply delayed.
2. The keypads are inactive during downloading communication, and resume normal functions after hang up. All keypad entries are ignored during on-line time.

**WHAT CAN BE DONE  
ONCE PANEL IS  
"ON-LINE"?**

- Arm the System in the Away Mode; Disarm the System
- Bypass a Zone
- Force the System to Accept a New Program Download
- Shut Down Communication (dialer) Functions (non-payment of monitoring fees in an owned system)
- Shut Down all Security System Functions (non-payment for a leased system)
- Inhibit Local Keypad Programming (prevents takeover of your accounts)
- Leave a message for customer
- Command the System to Upload a Copy of its Resident Program to the office
- Read: Arming Status, AC Power Status, List of Faulted Zones, List of Bypassed Zones, 224 Event Log, List of Zones Currently in Alarm, List of Zones Currently in Trouble
- Set the Real-Time clock.

**HOW SECURE IS  
DOWNLOADING?**

Accessing the Control from a remote location is protected against compromise by the use of 4 levels of protection:

1. Security Code Handshake: The subscriber's account number as well as an 8-digit ID number (known only to the office) must be matched between the Control and computer.
2. Hang-Up and Call-Back: The Control panel will "hang-up" and call the computer back at the pre-programmed number only if the security codes match.
3. Data Encryption: All data that is exchanged between the computer and Control is encrypted to reduce the possibility of anyone "tapping" the line and corrupting data.
4. Operator Access Levels: Up to 15 operators can have access to the DOWNLOADER, each having their own log-on code. However, each operator can be assigned one of three levels of access in both FILE and COMMAND functions, as follows:

**FILE ACCESS:**

Read Only: able only to look at the database; cannot change any information, and cannot see the customer's access codes.

Part Read/Write: able to look at and change all information, except the customer's access codes.

Full Read/Write: able to look at and change any and all information in the database.

**CONTROL/COMM ACCESS:**

Read Only: able only to Upload and arm the system. Not able to DISARM, BYPASS, or change any information.

Part Read/Write: able to ARM, BYPASS, UPLOAD, DOWNLOAD but cannot shutdown the system.

Full Read/Write: able to perform all control and status commands, as well as shutdown all or part of the system.

**NOTES:**

1. Each time the Control panel is accessed (whether successful or unsuccessful), a PROGRAM TAMPER report (\*81) is sent to central station, if programmed.
2. When downloading, the console displays "MODEM COMM".
3. Whenever a download or a save is done, an automatic time stamp is done, indicating the date and time of the last download (or save) and the operator ID number.
4. The average time for a complete download, including initial call-up, hang-up and call-back is under 4 minutes.
5. A complete hard copy of each individual account can be obtained by connecting a printer to the computer. Refer to your computer owner's manual or contact your dealer for printer recommendations.



## IX. TESTING THE SYSTEM

**BATTERY TEST** When AC power is present, the 5140XM will run a brief battery test every 60 seconds to determine if there is a battery connected, and will run an extended battery test every 24 hours to check on the battery's condition. If the 5140XI finds that the battery voltage is low (less than approx. 11.5V) during one of these tests, it initiates a console "System LoBat" display, a rapid console beeping sound, and it sends a low battery report to the central station (if the dialer feature is used). The console can be cleared by entering any security code + OFF, and a restore report will be sent to the central station after a subsequent test indicates that the problem (disconnected or low battery) has been corrected.

**DIALER TEST** The 5140XM may be programmed to automatically transmit test reports to a central station at intervals ranging from once per hour to once per 199 hours (field \*27). UL requires that a test report be transmitted at least once every 24 hours. The 5140XM can be programmed to send the first report at any time of the day, or at any day of the week after power up (field \*83)

**FIRE DRILL TEST  
(code + [#] + 69)** This test causes fire bells (or any bell having a non-zero response type in field 3\*10) to be activated (in either steady or pulsing manner as programmed in field 3\*15) for the purpose of conducting a fire drill or a bell test. This test can only be activated by the installer, or a master user by entering the corresponding security code and pressing [#] + 69 while the burglary portion of the system is disarmed. Consoles will display "FIRE DRILL ACTIVE" while this test is active. The test may be stopped by entering any security code and pressing OFF. Note that the system continues to monitor all 24 hour zones (fire, panic, etc.) while this test is active, and will end the test when an alarm condition is detected. This test should be conducted at periodic intervals as determined by the local authority having jurisdiction.

**ONE MAN FIRE WALK  
Test (code + [#] + 68)** This test causes the system to sound console beeps and bell dings in response to fire zone faults (zone type 9, 16 & 17) for the purpose of allowing proper zone operation to be checked without triggering alarms. Note that the system will not be operational as an alarm system (i.e. cannot sense alarms) while this test is active. The test can only be activated by the installer by entering the installer's code and pressing [#] + 68 while the burglary portion of the system is disarmed. This test should be conducted at periodic intervals as determined by the local authority having jurisdiction.

When this test is first activated, the system will sound fire bells (or any bell having a non-zero response type in field 3\*10) for 3 seconds. The system will also send a "Start of walk test" message to the central station, and will light all console indicators and display window segments to verify that they are working properly. The consoles will then display "Fire Walk Test in Progress" and will sound a single beep every 15 seconds while this test is active.

Fault and reset each fire alarm sensor in turn. Each action should cause consoles to beep and fire bells (or any bell assigned to the sensor's zone in fields 3\*70-3\*81) to ding. The consoles will display the zone number and the associated alpha descriptor while the zone remains faulted. The system automatically issues a smoke detector power reset about 10 seconds after it finds a fault on one of these zones, to allow faulted detectors to be reset.

The 4192CP, 4192SD & 4192SDT polling loop smoke detectors can also be tested by entering [#] + the detector's 2-digit ID (zone) number at the console. If a valid detector number is entered, the consoles will beep and fire bells will ding. The consoles will display the detector number for a few seconds. An invalid detector number will be ignored.

To end the test, enter any security code and press OFF. An end of walk test message will be sent to the central station. Note that the test will automatically end if no faults are detected within a 30 minute time period.

## **BURGLARY WALK TEST (code + TEST [5])**

This test causes the system to sound console beeps in response to faults on burglary and non-fire related 24 hour zones for the purpose of allowing proper zone operation to be checked without triggering alarms. Note that the system will not trigger alarms for burglary and non-fire related 24 hour zones but will trigger fire alarms while this test is active. This test can only be activated by the installer, a master user or manager user by entering the corresponding security code and pressing TEST while the burglary portion of the system is disarmed. UL requires that this test be conducted on a weekly basis.

When this test is first activated, the system will sound burglary bells (or any bell having 00 response type in field 3\*10) for 3 seconds. The system will send a start of walk test message to the central station. The consoles will display "Burg Walk Test in Progress" and will sound a single beep every 15 seconds while the test remains active.

Open and close each protected door and window in turn. Each action should produce 3 beeps from the console. Walk in front of any motion detectors. Listen for three beeps when the detector senses movement. The console will display the zone number and alpha descriptor while a door or window remains open or while a detector remains activated. The system automatically issues a zone 8 glass break detector power reset about 10 seconds after it finds a fault on this zone, to allow faulted detectors to be reset.

To end this test, enter any security code and press OFF. An end of walk test message will be sent to the central station.

## **ARMED BURGLARY SYSTEM TEST**

**IMPORTANT!** A message will be sent to the central station during the following tests. Notify the central station that a test will be in progress.

**NOTE:** A display of "COMM. FAILURE" indicates a failure to communicate (no KISSOFF by the receiver at the central station after the maximum number of transmission attempts is tried). If this occurs, verify that the phone line is connected, the correct report format is programmed, etc.

1. Arm the system and fault one or more zones. Silence alarm sounder(s) each time by entering the code and pressing OFF. Check that Entry/Exit delay zones provide the assigned delay times.
2. Check the keypad-initiated alarms, if programmed in field \*05, by pressing the Panic keys (\* and #, 1 and \*, and/or 3 and #). If the system has been programmed for audible emergency, the console will emit a loud, steady alarm sound. The word ALARM and a descriptor "99" will be displayed for \* and #. (if 1 and \* are pressed, a "95" will be displayed; if 3 and # are pressed, a "96" will be displayed). Silence the alarm by entering the security code and pressing OFF. If the system has been programmed for silent panic, there will be no audible alarms or displays. A report will be sent to the central station, however.
3. Notify the central station that all tests are finished and verify results with them.

## **TURNING THE SYSTEM OVER TO THE USER**

1. Fully explain the operation of the system to the user by going over each of its functions as well as the User's Manual supplied.
2. In particular, explain the operation of each zone (entry/exit, perimeter, interior, fire, etc.). Be sure the user understands how to operate any emergency feature(s) programmed into the system.

**IMPORTANT!:** In the spaces provided in the User's Manual, record the Entry and Exit Delay times, and those functions that have been programmed into the available pairs of PANIC keys (\* & #, 1 & \*, 3 & #).

3. Make sure the user understands the importance of testing the burglary system at least weekly, following the procedure provided in the User's Manual.

### **TO THE INSTALLER**

Regular maintenance and inspection (at least annually) by the installer and frequent testing by the user are vital to continuous satisfactory operation of any alarm system.

The installer should assume the responsibility of developing and offering a regular maintenance program to the user as well as acquainting the user with the proper operation and limitations of the alarm system and its component parts. Recommendations must be included for a specific program of frequent testing (at least weekly) to insure the system's proper operation at all times.

## X. REGULATORY AGENCY REQUIREMENTS

NOTE 1: Set field 3\*82 to "0" to disable burglary features if burglary protection will not be installed (disables AWAY, STAY, MAXIMUM, INSTANT, TEST and CHIME key functions).

NOTE 2: The sections in brackets [ ] provide more detailed wiring and programming instructions.

NOTE 3: For fire only or combination fire and burglary installations, AC loss reports must be transmitted to the central station between 6 & 12 hours after loss of AC power (field \*19=2), and neither bell 1 or bell 2 should ring an alarm 4 hours after loss of AC power (fields \*18, 3\*58=0). For burglary only installations, AC loss must be transmitted less than 6 hours after loss of power (field \*19=0 or 1), and either bell 1 or bell 2 should ring an alarm 4 hours after loss of power (field \*18 or 3\*58=1).

### UL864/NFPA72A Local Fire

- Configure at least one bell output for supervision and wire polarized fire alarm indicators to it. Program this bell for pulsed operation when burglary protection will be installed [BELL OUTPUTS].

### UL864/NFPA71 Central Station

- You may use a 7620ULF or 7920SE LORRAs alone, the main dialer with the LORRA, or the main dialer with the 5140DLM Backup Dialer Module. Refer to the LORRA Installation Instructions for more detailed information.
- When using the LORRA, connect its channel inputs to the 5140XM's Fire Alarm, Fire Supervisory (if installed) and Trouble Triggers. Also connect its XMIT OKAY output to the 5140XM's J2/Input 1 input. Program J2/Input 1 zone 73 for a 24 hour trouble response (type 19) to radio faults (see TRIGGER OUTPUTS section).
- When the main dialer is used, enable it (field 3\*30) and connect it to a telephone line. Assign a 24 hour trouble response (type 19) to zone 74 to enable main dialer supervision (field 3\*10) (see DIALER OUTPUTS section). The 5140XM will activate the trouble trigger to trip the LORRA (if used) when the main dialer is faulted.
- When the 5140DLM Backup Dialer Module is used, install it on the 5140XM's PC board shield. Enable it (field 3\*30) and connect it to a separate telephone line. Assign a 24 hour trouble response (type 19) to zone 75 to enable backup dialer supervision (field 3\*10) (see DIALER OUTPUTS section).
- When a dialer is used, program it to send fire alarm, fire supervisory, trouble, AC loss and communicator test reports. Field \*27 must be set to "024" (or less) so that test reports are sent at least once every 24 hours.
- If a secondary phone number is programmed (field \*34) then the maximum number of dialer retries (field 3\*21) must be restricted to 3, 4 or 5.

### UL609 Grade A Local Mercantile Premises/Local Mercantile Safe and Vault

- Configure one bell output for no supervision and wire an AB12 grade A bell/box to it. Bell wires must be run in conduit. Program this bell for steady alarm sounding, 16 or more minute timeout, and for confirmation of arming ding [BELL OUTPUTS].
- Attach a door tamper switch (supplied) to the 5140XM back-box. For safe and vault installations, a shock sensor (not supplied) must also be attached to the back-box [MOUNTING THE CABINET].
- Wire the bell box and 5140XM cabinet tamper switches (and shock sensor, if used) to zone 6. Select the zone 6 alternate tamper function (field 3\*17=1) and assign zone 6 a day/night response.

- Entry delays must not exceed 45 seconds and exit delays must not exceed 60 seconds.
- If 4190WH RPMs are used, set field \*24 to "0" to enable tamper detection. See the POLLING LOOP section for notes regarding the use of RPMs for monitoring fire and burglary sensors.

### UL 365 Police Station Connected Burglar Alarm

- Follow the instructions for UL 609 local installations

#### For Grade A Service:

- You may use the main dialer alone, the main dialer with the 5140DLM Back-up dialer module, the 7620ULF (or 7720) LORRA alone or the 346 polarity reversal relay.
- When using the main dialer alone, program it to send burglary alarm, low battery and communicator test reports. Field \*27 must be set to "024" (or less) so that test reports are sent at least once every 24 hours.
- When using the main dialer with the 5140DLM back-up dialer module, assign a 24 hour trouble response (type 19) to zones 74 and 75 (field 3\*10) to enable supervision for both dialers. Program the dialer to send burglary alarm, trouble and low battery reports (see DIALER OUTPUTS section).
- When the 7620ULF (or 7720) LORRA or 346 polarity reversal relay is used, connect it to the 5140XM's burglary/audible panic alarm trigger (see TRIGGER OUTPUTS section).

#### For Grade AA Service:

- You may use a 7920SE LORRA alone or a 445 high line security transmitter.
- Connect the 7920SE LORRA or the 445 transmitter to the 5140XM's burglary/audible panic alarm trigger (see TRIGGER OUTPUTS section).

### UL611/UL 1610 Central Station Burglar Alarm

- Follow the instructions for UL 609 local installations

#### For Grade A Service:

- You must use the main dialer with the 7620ULF (or 7720) LORRA.
- Connect the 7620ULF's input channels to the 5140XM's burglary/audible panic alarm and trouble triggers. Also connect the 7620ULF's "XMIT OK" output to the 5140XM's J2/Input 1 input. Program J2/Input 1 zone 73 for a 24 hour trouble response (type 19) to radio faults (see TRIGGER OUTPUTS section).
- Enable the main dialer (field 3\*30) and connect it to a telephone line. Assign a 24 hour trouble response (type 19) to zone 74 to enable main dialer supervision (field 3\*10). The 5140XM will activate the trouble trigger to trip the 7620ULF when the main dialer is faulted (see DIALER OUTPUTS section).
- Program the dialer to send burglary alarm, trouble, opening/closing and low battery reports.

#### For Grade AA Service:

- Follow the instructions for Grade A installation except use the 7920SE in place of the 7620ULF.

### New York City Requirements

New York City Fire Department prohibits commercial combination fire/burglary panels. When using the 5140XM for fire protection, burglary protection cannot be implemented.

## 4190WH OPERATION & WIRING DIAGRAM

The 4190WH is a 2-zone (known as left and right zones) RPM. The left zone can be used for closed-circuit devices, and for open-circuit devices, with EOLR supervision. The left zone can also be used with fast-response (10 millisecond) devices, if necessary. Follow the chart at right for cutting the correct jumpers and choosing the correct resistor when using the left zone.

The right zone is unsupervised and cannot be used.

**IMPORTANT:** The tamper/supervision response of the 4190WH is determined by the zone response type assigned to the **left** loop. While the system is disarmed, tamper/supervisory faults will **always** report as trouble messages. While the system is armed, tamper/supervisory faults will report as troubles if the left loop is assigned a non-burglary response type (i.e. fire, panic, aux), and will report as alarms if assigned a burglary response type.

### JUMPERS USAGE (LEFT ZONE ONLY)

- RED:** Cut for fast-response (10 millisecond).
- WHITE:** Cut for low current mode. Suitable for sealed reed type switches. May be used for N.O. or N.C. burglary contacts only. Use the 30k EOLR provided. The 4190WH draws 1 mA from the polling loop in this mode.
- BLUE:** Leave intact.
- NONE CUT:** High current mode. Suitable for mechanical switches. May be used for N.O. fire contacts when model 610-11, 4.7k fire EOLR is used (purchase 4100EOLR kit). May also be used for N.O. or N.C. burglary contacts. Use the 4.7k EOLR provided. The 4190WH draws 2 mA from the polling loop in this mode.

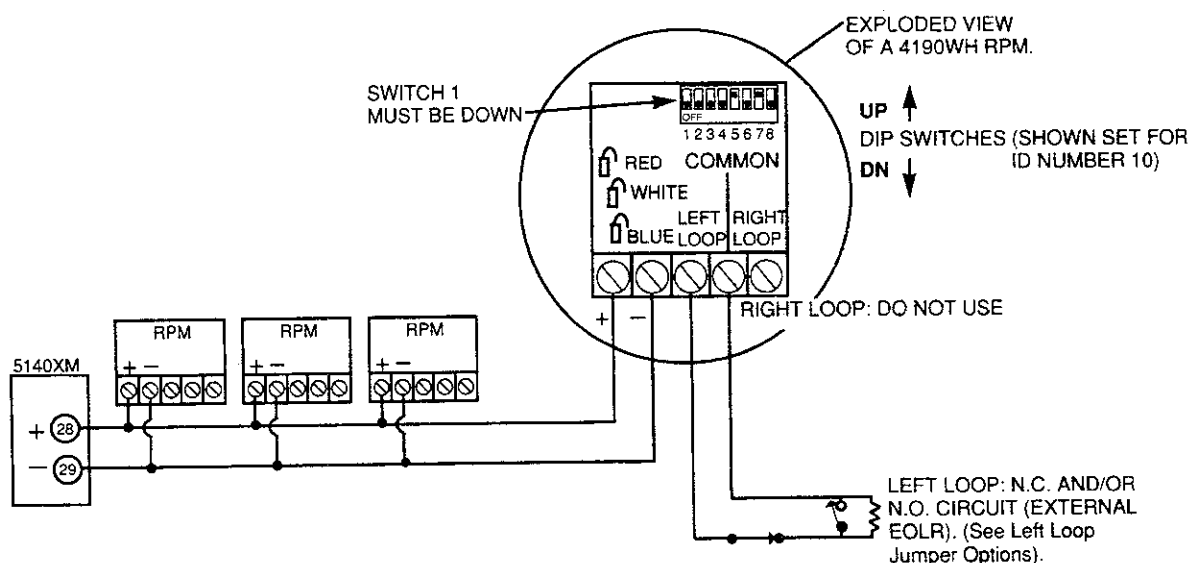
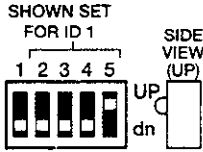
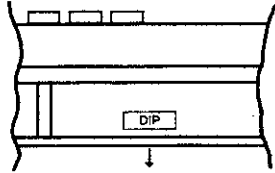

Figure 20.

**DIP SWITCH TABLES FOR ADDRESSABLE CONSOLES AND POLLING LOOP DEVICES**

**Addressable Consoles  
(e.g. 5137AD)**



↑ **IMPORTANT:** USE ID 31 FOR APPLICATIONS NOT REQUIRING ADDRESSABLE CONSOLES.

**4208 Zone Expander**

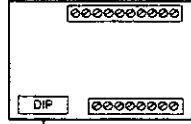

SHOWN SET FOR ID 10-16 (A)

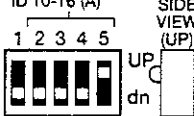

POS. 1: LOOPS 1 & 2 RESPONSE TIME:

W/TABLE	FAST	SLOW
A	UP	dn
B	dn	UP

**4192SD/4192SDT/  
4192CP  
Smoke Detectors**

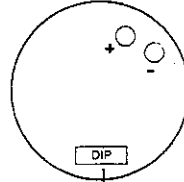

APPLIES TO TABLE A ONLY  
SHOWN SET FOR ID 10



POS. 1: MUST BE dn

**4190WH Zone Expander**

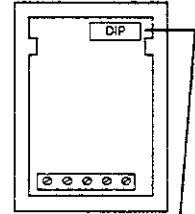

APPLIES TO TABLES A & B  
SHOWN SET FOR ID 10(A)



WITH TABLE: A B  
POS. 1 MUST BE: dn UP

DEVICE ID	DIP SWITCH POSITION				
	1	2	3	4	5
0	dn	dn	dn	dn	dn
1	dn	dn	dn	dn	UP
2	dn	dn	dn	UP	dn
3	dn	dn	dn	UP	UP
4	dn	dn	UP	dn	dn
5	dn	dn	UP	dn	UP
6	dn	dn	UP	UP	dn
7	dn	dn	UP	UP	UP
8	dn	UP	dn	dn	dn
9	dn	UP	dn	dn	UP
10	dn	UP	dn	UP	dn
11	dn	UP	dn	UP	UP
12	dn	UP	UP	dn	dn
13	dn	UP	UP	dn	UP
14	dn	UP	UP	UP	dn
15	dn	UP	UP	UP	UP
16	UP	dn	dn	dn	dn
17	UP	dn	dn	dn	UP
18	UP	dn	dn	UP	dn
19	UP	dn	dn	UP	UP
20	UP	dn	UP	dn	dn
21	UP	dn	UP	dn	UP
22	UP	dn	UP	UP	dn
23	UP	dn	UP	UP	UP
24	UP	UP	dn	dn	dn
25	UP	UP	dn	dn	UP
26	UP	UP	dn	UP	dn
27	UP	UP	dn	UP	UP
28	UP	UP	UP	dn	dn
29	UP	UP	UP	dn	UP
30	UP	UP	UP	UP	dn
31	UP	UP	UP	UP	UP

BIT VALUE: 16 8 4 2 1

**THIS TABLE FOR DIPS WITH WORD "OFF"**

DEVICE ID	DIP SWITCH POSITION			
	2	3	4	5
9-16	dn	dn	dn	UP
17-24	dn	dn	UP	dn
25-32	dn	dn	UP	UP
33-40	dn	UP	dn	dn
41-48	dn	UP	dn	UP
49-56	dn	UP	UP	dn
57-64	dn	UP	UP	UP

**THIS TABLE FOR DIPS WITH WORD "ON"**

DEVICE ID	DIP SWITCH POSITION			
	2	3	4	5
9-16	UP	UP	UP	dn
17-24	UP	UP	dn	UP
25-32	UP	UP	dn	dn
33-40	UP	dn	UP	UP
41-48	UP	dn	UP	dn
49-56	UP	dn	dn	UP
57-64	UP	dn	dn	dn

**THIS TABLE FOR DIPS WITH WORD "OFF"**

DEVICE ID	DIP SWITCH POSITION							
	2	3	4	5	6	7	8	
9	dn	dn	dn	UP	dn	dn	UP	
10	dn	dn	dn	UP	dn	UP	dn	
11	dn	dn	dn	UP	dn	UP	UP	
12	dn	dn	dn	UP	UP	dn	dn	
13	dn	dn	dn	UP	UP	dn	UP	
14	dn	dn	dn	UP	UP	UP	dn	
15	dn	dn	dn	UP	UP	UP	UP	
16	dn	dn	UP	dn	dn	dn	dn	
17	dn	dn	UP	dn	dn	dn	UP	
18	dn	dn	UP	dn	dn	UP	dn	
19	dn	dn	UP	dn	dn	UP	UP	
20	dn	dn	UP	dn	UP	dn	dn	
21	dn	dn	UP	dn	UP	dn	UP	
22	dn	dn	UP	dn	UP	UP	dn	
23	dn	dn	UP	dn	UP	UP	UP	
24	dn	dn	UP	UP	dn	dn	dn	
25	dn	dn	UP	UP	dn	dn	UP	
26	dn	dn	UP	UP	dn	UP	dn	
27	dn	dn	UP	UP	dn	UP	UP	
28	dn	dn	UP	UP	dn	dn	dn	
29	dn	dn	UP	UP	dn	UP	UP	
30	dn	dn	UP	UP	UP	dn	dn	
31	dn	dn	UP	UP	UP	UP	UP	
32	dn	UP	dn	dn	dn	dn	dn	
33	dn	UP	dn	dn	dn	dn	UP	
34	dn	UP	dn	dn	dn	UP	dn	
35	dn	UP	dn	dn	dn	UP	UP	
36	dn	UP	dn	dn	UP	dn	dn	
37	dn	UP	dn	dn	UP	dn	UP	
38	dn	UP	dn	dn	UP	UP	dn	
39	dn	UP	dn	dn	UP	UP	UP	
40	dn	UP	dn	UP	dn	dn	dn	
41	dn	UP	dn	UP	dn	dn	UP	
42	dn	UP	dn	UP	dn	UP	dn	
43	dn	UP	dn	UP	dn	UP	UP	
44	dn	UP	dn	UP	dn	UP	dn	
45	dn	UP	dn	UP	dn	UP	UP	
46	dn	UP	dn	UP	UP	dn	dn	
47	dn	UP	dn	UP	UP	UP	UP	
48	dn	UP	dn	UP	dn	dn	dn	
49	dn	UP	dn	UP	dn	dn	UP	
50	dn	UP	UP	dn	dn	UP	dn	
51	dn	UP	UP	dn	dn	UP	UP	
52	dn	UP	UP	dn	UP	dn	dn	
53	dn	UP	UP	dn	UP	dn	UP	
54	dn	UP	UP	dn	UP	dn	UP	
55	dn	UP	UP	dn	UP	UP	UP	
56	dn	UP	UP	UP	dn	dn	dn	
57	dn	UP	UP	UP	dn	dn	UP	
58	dn	UP	UP	UP	dn	UP	dn	
59	dn	UP	UP	UP	dn	UP	UP	
60	dn	UP	UP	UP	dn	dn	dn	
61	dn	UP	UP	UP	dn	dn	UP	
62	dn	UP	UP	UP	UP	dn	dn	
63	dn	UP	UP	UP	UP	dn	dn	
64	UP	dn	dn	dn	dn	dn	dn	

BIT VALUE: 64 32 16 8 4 2 1

**THIS TABLE FOR DIPS WITH WORD "ON"**

DEVICE ID	DIP SWITCH POSITION							
	2	3	4	5	6	7	8	
9	UP	UP	UP	dn	UP	UP	dn	
10	UP	UP	UP	dn	UP	dn	UP	
11	UP	UP	UP	dn	UP	dn	dn	
12	UP	UP	UP	dn	UP	dn	UP	
13	UP	UP	UP	dn	dn	UP	dn	
14	UP	UP	UP	dn	dn	dn	UP	
15	UP	UP	UP	dn	dn	dn	dn	
16	UP	UP	dn	UP	UP	UP	UP	
17	UP	UP	dn	UP	UP	UP	dn	
18	UP	UP	dn	UP	UP	dn	UP	
19	UP	UP	dn	UP	UP	dn	dn	
20	UP	UP	dn	UP	dn	UP	UP	
21	UP	UP	dn	UP	dn	UP	dn	
22	UP	UP	dn	UP	dn	dn	dn	
23	UP	UP	dn	UP	dn	dn	dn	
24	UP	UP	dn	UP	UP	UP	UP	
25	UP	UP	dn	UP	UP	dn	dn	
26	UP	UP	dn	UP	dn	UP	dn	
27	UP	UP	dn	UP	dn	UP	dn	
28	UP	UP	dn	UP	UP	UP	UP	
29	UP	UP	dn	UP	dn	UP	dn	
30	UP	UP	dn	UP	dn	dn	dn	
31	UP	UP	dn	UP	dn	dn	dn	
32	UP	UP	dn	UP	UP	UP	UP	
33	UP	UP	dn	UP	UP	UP	UP	
34	UP	UP	dn	UP	UP	UP	dn	
35	UP	UP	dn	UP	UP	UP	dn	
36	UP	UP	dn	UP	UP	dn	UP	
37	UP	UP	dn	UP	UP	dn	dn	
38	UP	UP	dn	UP	UP	dn	dn	
39	UP	UP	dn	UP	UP	dn	dn	
40	UP	UP	dn	UP	dn	UP	UP	
41	UP	UP	dn	UP	dn	UP	dn	
42	UP	UP	dn	UP	dn	UP	dn	
43	UP	UP	dn	UP	dn	UP	dn	
44	UP	UP	dn	UP	dn	UP	dn	
45	UP	UP	dn	UP	dn	UP	UP	
46	UP	UP	dn	UP	dn	dn	dn	
47	UP	UP	dn	UP	dn	dn	dn	
48	UP	UP	dn	UP	UP	UP	UP	
49	UP	UP	dn	UP	dn	dn	UP	
50	UP	UP	dn	UP	dn	UP	UP	
51	UP	UP	dn	UP	dn	UP	dn	
52	UP	UP	dn	UP	dn	UP	dn	
53	UP	UP	dn	UP	dn	UP	dn	
54	UP	UP	dn	UP	dn	UP	UP	
55	UP	UP	dn	UP	dn	UP	dn	
56	UP	UP	dn	UP	UP	dn	dn	
57	UP	UP	dn	UP	UP	dn	UP	
58	UP	UP	dn	UP	UP	dn	dn	
59	UP	UP	dn	UP	UP	dn	dn	
60	UP	UP	dn	UP	dn	dn	UP	
61	UP	UP	dn	UP	dn	dn	UP	
62	UP	UP	dn	UP	dn	dn	dn	
63	UP	UP	dn	UP	dn	dn	dn	
64	UP	UP	dn	UP	UP	UP	UP	

BIT VALUE: 64 32 16 8 4 2 1

## DIP SWITCH TABLES FOR POLLING LOOP DEVICES

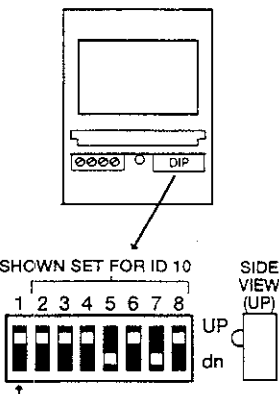
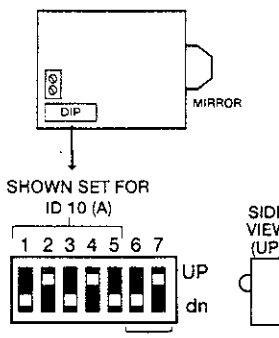
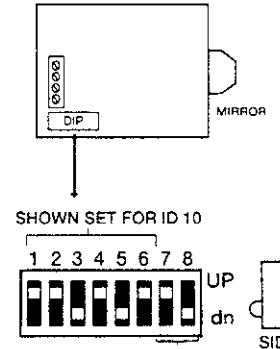
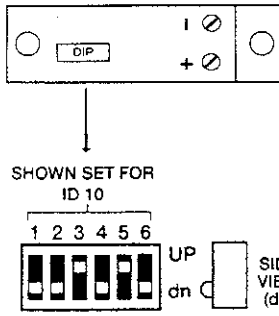
<p style="text-align: center;"><b>4196 PIR</b></p>  <p style="text-align: center;">SHOWN SET FOR ID 10</p> <p style="text-align: center;">POS. 1: MUST BE UP</p>	<p style="text-align: center;"><b>4275 PIR</b></p>  <p style="text-align: center;">SHOWN SET FOR ID 10 (A)</p> <p>POS. 6: UP (A), dn (B) = INST. MODE dn (A), UP (B) = PULSE COUNT</p> <p>POS. 7: UP (A), dn (B) = WALK TEST dn (A), UP (B) = W/T DISABLE</p>	<p style="text-align: center;"><b>4278 PIR</b></p>  <p style="text-align: center;">SHOWN SET FOR ID 10</p> <p>POS. 7: UP = NORMAL MODE dn = INSTANT MODE</p> <p>POS. 8: UP = W/T DISABLE dn = WALK TEST</p>	<p style="text-align: center;"><b>4194 Reed Contact (Surface Mount)</b></p>  <p style="text-align: center;">SHOWN SET FOR ID 10</p>
---	--	---	--

DEVICE ID	DIP SWITCH POSITION							
	2	3	4	5	6	7	8	
9	UP	UP	UP	dn	UP	UP	dn	
10	UP	UP	UP	dn	UP	dn	UP	
11	UP	UP	UP	dn	UP	dn	dn	
12	UP	UP	UP	dn	dn	UP	UP	
13	UP	UP	UP	dn	dn	UP	dn	
14	UP	UP	UP	dn	dn	dn	UP	
15	UP	UP	UP	dn	dn	dn	dn	
16	UP	UP	dn	UP	UP	UP	UP	
17	UP	UP	dn	UP	UP	UP	dn	
18	UP	UP	dn	UP	UP	dn	UP	
19	UP	UP	dn	UP	UP	dn	dn	
20	UP	UP	dn	UP	UP	dn	UP	
21	UP	UP	dn	UP	dn	UP	dn	
22	UP	UP	dn	UP	dn	dn	UP	
23	UP	UP	dn	UP	dn	dn	dn	
24	UP	UP	dn	dn	UP	UP	UP	
25	UP	UP	dn	dn	UP	UP	dn	
26	UP	UP	dn	dn	UP	dn	UP	
27	UP	UP	dn	dn	UP	dn	dn	
28	UP	UP	dn	dn	dn	UP	UP	
29	UP	UP	dn	dn	dn	UP	dn	
30	UP	UP	dn	dn	dn	dn	UP	
31	UP	UP	dn	dn	dn	dn	dn	
32	UP	dn	UP	UP	UP	UP	UP	
33	UP	dn	UP	UP	UP	UP	dn	
34	UP	dn	UP	UP	UP	UP	UP	
35	UP	dn	UP	UP	UP	UP	dn	
36	UP	dn	UP	UP	UP	UP	UP	
37	UP	dn	UP	UP	UP	UP	dn	
38	UP	dn	UP	UP	UP	UP	UP	
39	UP	dn	UP	UP	UP	UP	dn	
40	UP	dn	UP	UP	UP	UP	UP	
41	UP	dn	UP	UP	UP	UP	UP	
42	UP	dn	UP	UP	UP	UP	UP	
43	UP	dn	UP	UP	UP	UP	dn	
44	UP	dn	UP	UP	UP	UP	UP	
45	UP	dn	UP	UP	UP	UP	dn	
46	UP	dn	UP	UP	UP	UP	UP	
47	UP	dn	UP	UP	UP	UP	dn	
48	UP	dn	UP	UP	UP	UP	UP	
49	UP	dn	UP	UP	UP	UP	UP	
50	UP	dn	UP	UP	UP	UP	UP	
51	UP	dn	UP	UP	UP	UP	UP	
52	UP	dn	UP	UP	UP	UP	UP	
53	UP	dn	UP	UP	UP	UP	UP	
54	UP	dn	UP	UP	UP	UP	UP	
55	UP	dn	UP	UP	UP	UP	UP	
56	UP	dn	UP	UP	UP	UP	UP	
57	UP	dn	UP	UP	UP	UP	UP	
58	UP	dn	UP	UP	UP	UP	UP	
59	UP	dn	UP	UP	UP	UP	UP	
60	UP	dn	UP	UP	UP	UP	UP	
61	UP	dn	UP	UP	UP	UP	UP	
62	UP	dn	UP	UP	UP	UP	UP	
63	UP	dn	UP	UP	UP	UP	UP	
64	dn	UP	UP	UP	UP	UP	UP	
BIT VALUE	64	32	16	8	4	2	1	

**THIS TABLE FOR DIPS WITH WORD \*OFF\***

DEVICE ID	DIP SWITCH POSITION				
	1	2	3	4	5
9	dn	UP	dn	dn	UP
10	dn	UP	dn	UP	dn
11	dn	UP	dn	UP	UP
12	dn	UP	UP	dn	dn
13	dn	UP	UP	dn	UP
14	dn	UP	UP	dn	UP
15	dn	UP	UP	UP	UP
16	UP	dn	dn	dn	dn
17	UP	dn	dn	dn	UP
18	UP	dn	dn	UP	UP
19	UP	dn	dn	UP	UP
20	UP	dn	UP	dn	dn
21	UP	dn	UP	dn	UP
22	UP	dn	UP	UP	dn
23	UP	dn	UP	UP	UP
24	UP	UP	dn	dn	dn
25	UP	UP	dn	dn	UP
26	UP	UP	dn	UP	dn
27	UP	UP	dn	UP	UP
28	UP	UP	UP	dn	dn
29	UP	UP	UP	dn	UP
30	UP	UP	UP	UP	dn
31	UP	UP	UP	UP	UP

**THIS TABLE FOR DIPS WITH WORD \*ON\***

DEVICE ID	DIP SWITCH POSITION				
	1	2	3	4	5
9	UP	dn	UP	UP	dn
10	UP	dn	UP	dn	UP
11	UP	dn	UP	dn	dn
12	UP	dn	UP	UP	dn
13	UP	dn	UP	UP	UP
14	UP	dn	UP	dn	dn
15	UP	dn	UP	dn	UP
16	dn	UP	UP	UP	UP
17	dn	UP	UP	UP	dn
18	dn	UP	UP	UP	UP
19	dn	UP	UP	UP	UP
20	dn	UP	UP	UP	UP
21	dn	UP	UP	UP	UP
22	dn	UP	UP	UP	UP
23	dn	UP	UP	UP	UP
24	dn	UP	UP	UP	UP
25	dn	UP	UP	UP	UP
26	dn	UP	UP	UP	UP
27	dn	UP	UP	UP	UP
28	dn	UP	UP	UP	UP
29	dn	UP	UP	UP	UP
30	dn	UP	UP	UP	UP
31	dn	UP	UP	UP	UP

BIT VALUE: 16 8 4 2 1

DEVICE ID	DIP SWITCH POSITION					
	1	2	3	4	5	6
9	UP	UP	dn	UP	UP	dn
10	UP	UP	dn	UP	dn	UP
11	UP	UP	dn	UP	dn	dn
12	UP	UP	dn	dn	UP	UP
13	UP	UP	dn	dn	UP	dn
14	UP	UP	dn	dn	dn	UP
15	UP	UP	dn	dn	dn	dn
16	UP	dn	UP	UP	UP	UP
17	UP	dn	UP	UP	UP	dn
18	UP	dn	UP	UP	UP	UP
19	UP	dn	UP	UP	dn	dn
20	UP	dn	UP	UP	UP	UP
21	UP	dn	UP	UP	UP	UP
22	UP	dn	UP	UP	dn	UP
23	UP	dn	UP	UP	dn	dn
24	UP	dn	UP	UP	UP	UP
25	UP	dn	UP	UP	UP	dn
26	UP	dn	UP	UP	dn	UP
27	UP	dn	UP	UP	dn	dn
28	UP	dn	UP	UP	UP	UP
29	UP	dn	UP	UP	UP	dn
30	UP	dn	UP	UP	UP	UP
31	UP	dn	UP	UP	UP	UP
32	dn	UP	UP	UP	UP	UP
33	dn	UP	UP	UP	UP	dn
34	dn	UP	UP	UP	UP	UP
35	dn	UP	UP	UP	UP	dn
36	dn	UP	UP	UP	UP	UP
37	dn	UP	UP	UP	UP	dn
38	dn	UP	UP	UP	UP	UP
39	dn	UP	UP	UP	UP	UP
40	dn	UP	UP	UP	UP	UP
41	dn	UP	UP	UP	UP	UP
42	dn	UP	UP	UP	UP	UP
43	dn	UP	UP	UP	UP	UP
44	dn	UP	UP	UP	UP	UP
45	dn	UP	UP	UP	UP	UP
46	dn	UP	UP	UP	UP	UP
47	dn	UP	UP	UP	UP	UP
48	dn	UP	UP	UP	UP	UP
49	dn	UP	UP	UP	UP	UP
50	dn	UP	UP	UP	UP	UP
51	dn	UP	UP	UP	UP	UP
52	dn	UP	UP	UP	UP	UP
53	dn	UP	UP	UP	UP	UP
54	dn	UP	UP	UP	UP	UP
55	dn	UP	UP	UP	UP	UP
56	dn	UP	UP	UP	UP	UP
57	dn	UP	UP	UP	UP	UP
58	dn	UP	UP	UP	UP	UP
59	dn	UP	UP	UP	UP	UP
60	dn	UP	UP	UP	UP	UP
61	dn	UP	UP	UP	UP	UP
62	dn	UP	UP	UP	UP	UP
63	dn	UP	UP	UP	UP	UP

BIT VALUE: 32 16 8 4 2 1

DEVICE ID	DIP SWITCH POSITION					
	1	2	3	4	5	6
9	dn	dn	UP	dn	dn	UP
10	dn	dn	UP	dn	UP	dn
11	dn	dn	UP	dn	UP	UP
12	dn	dn	UP	UP	dn	dn
13	dn	dn	UP	UP	UP	UP
14	dn	dn	UP	UP	UP	dn
15	dn	dn	UP	UP	UP	UP
16	dn	UP	dn	dn	dn	dn
17	dn	UP	dn	dn	dn	UP
18	dn	UP	dn	dn	UP	dn
19	dn	UP	dn	dn	UP	UP
20	dn	UP	dn	dn	UP	dn
21	dn	UP	dn	UP	dn	UP
22	dn	UP	dn	UP	UP	dn
23	dn	UP	dn	UP	UP	UP
24	dn	UP	dn	UP	dn	dn
25	dn	UP	UP	dn	dn	UP
26	dn	UP	UP	dn	UP	dn
27	dn	UP	UP	dn	UP	UP
28	dn	UP	UP	UP	dn	dn
29	dn	UP	UP	UP	UP	UP
30	dn	UP	UP	UP	UP	dn
31	dn	UP	UP	UP	UP	UP
32	UP	dn	dn	dn	dn	dn
33	UP	dn	dn	dn	dn	dn
34	UP	dn	dn	dn	UP	dn
35	UP	dn	dn	dn	UP	UP
36	UP	dn	dn	UP	dn	dn
37	UP	dn	dn	UP	dn	UP
38	UP	dn	dn	UP	UP	dn
39	UP	dn	dn	UP	UP	UP
40	UP	dn	UP	dn	dn	dn
41	UP	dn	UP	dn	UP	UP
42	UP	dn	UP	dn	UP	dn
43	UP	dn	UP	dn	UP	UP
44	UP	dn	UP	UP	dn	dn
45	UP	dn	UP	UP	UP	UP
46	UP	dn	UP	UP	UP	UP
47	UP	dn	UP	UP	UP	UP
48	UP	UP	dn	dn	dn	dn
49	UP	UP	dn	dn	dn	UP
50	UP	UP	dn	dn	UP	dn
51	UP	UP	dn	dn	UP	UP
52	UP	UP	dn	UP	dn	dn
53	UP	UP	dn	UP	UP	UP
54	UP	UP	dn	UP	UP	UP
55	UP	UP	dn	UP	UP	UP
56	UP	UP	dn	UP	UP	UP
57	UP	UP	dn	UP	UP	UP
58	UP	UP	dn	UP	UP	UP
59	UP	UP	dn	UP	UP	UP
60	UP	UP	dn	UP	UP	UP
61	UP	UP	dn	UP	UP	UP
62	UP	UP	dn	UP	UP	UP
63	UP	UP	dn	UP	UP	UP

BIT VALUE: 32 16 8 4 2 1

**COMMUNICATION DEFAULTS for LOW SPEED FORMAT (\*94\*80)**

*45 PRIMARY FORMAT	<input type="checkbox"/> 0	Ademco Low Speed	*51 DUAL REPORTING	<input type="checkbox"/> 0	no					
*46 LOW SPEED FORMAT (Primary)	<input type="checkbox"/> 0	Ademco Low Speed	*52 STANDARD/EXPANDED REPORT FOR PRIMARY	<input type="checkbox"/> 0	<input type="checkbox"/> 0	<input type="checkbox"/> 0	<input type="checkbox"/> 0	<input type="checkbox"/> 0	<input type="checkbox"/> 0	standard
*47 SECONDARY FORMAT	<input type="checkbox"/> 0	Ademco Low Speed	Alarm Rstr Bypass Trbl Opn/Cls Low Bat							
*48 LOW SPEED FORMAT (Sec.)	<input type="checkbox"/> 0	Ademco Low Speed	Fire Supv							Walk Test
*49 CHECKSUM VERIFICATION	<input type="checkbox"/> 0	<input type="checkbox"/> 0	*53 STANDARD/EXPANDED REPORT FOR SECONDARY	<input type="checkbox"/> 0	<input type="checkbox"/> 0	<input type="checkbox"/> 0	<input type="checkbox"/> 0	<input type="checkbox"/> 0	<input type="checkbox"/> 0	standard
No checksum		Primary Secondary	Alarm Rstr Bypass Trbl Opn/Cls Low Bat							
*50 SESCO/RADIONICS SELECT	<input type="checkbox"/> 0	Radionics	Fire Supv							Walk Test

**ALARM/FIRE SUPV REPORT CODES/ID DIGITS & TRB/BYP/RESTORE CODES FOR ZONES 1-32**

*54 CODE	*55 ID	*56 CODE	*57 ID	*58	*59 CODE	*60 ID	*61 CODE	*62 ID	*63
1 <input type="checkbox"/> 0 1	<input type="checkbox"/> 0 0	9 <input type="checkbox"/> 0 3	<input type="checkbox"/> 0 0	<input type="checkbox"/> 0 9 Alm/supv rst.	17 <input type="checkbox"/> 0 3	<input type="checkbox"/> 0 0	25 <input type="checkbox"/> 0 3	<input type="checkbox"/> 0 0	<input type="checkbox"/> 0 9 Alm/supv rst.
2 <input type="checkbox"/> 0 1	<input type="checkbox"/> 0 0	10 <input type="checkbox"/> 0 3	<input type="checkbox"/> 0 0	<input type="checkbox"/> 0 5 Trouble	18 <input type="checkbox"/> 0 3	<input type="checkbox"/> 0 0	26 <input type="checkbox"/> 0 3	<input type="checkbox"/> 0 0	<input type="checkbox"/> 0 5 Trouble
3 <input type="checkbox"/> 0 3	<input type="checkbox"/> 0 0	11 <input type="checkbox"/> 0 3	<input type="checkbox"/> 0 0	<input type="checkbox"/> 0 9 Trble Rst.	19 <input type="checkbox"/> 0 3	<input type="checkbox"/> 0 0	27 <input type="checkbox"/> 0 3	<input type="checkbox"/> 0 0	<input type="checkbox"/> 0 9 Trble Rst.
4 <input type="checkbox"/> 0 3	<input type="checkbox"/> 0 0	12 <input type="checkbox"/> 0 3	<input type="checkbox"/> 0 0	<input type="checkbox"/> 0 0 Bypass	20 <input type="checkbox"/> 0 3	<input type="checkbox"/> 0 0	28 <input type="checkbox"/> 0 3	<input type="checkbox"/> 0 0	<input type="checkbox"/> 0 0 Bypass
5 <input type="checkbox"/> 0 3	<input type="checkbox"/> 0 0	13 <input type="checkbox"/> 0 3	<input type="checkbox"/> 0 0	<input type="checkbox"/> 0 0 Byppss Rst.	21 <input type="checkbox"/> 0 3	<input type="checkbox"/> 0 0	29 <input type="checkbox"/> 0 3	<input type="checkbox"/> 0 0	<input type="checkbox"/> 0 0 Byppss Rst.
6 <input type="checkbox"/> 0 3	<input type="checkbox"/> 0 0	14 <input type="checkbox"/> 0 3	<input type="checkbox"/> 0 0		22 <input type="checkbox"/> 0 3	<input type="checkbox"/> 0 0	30 <input type="checkbox"/> 0 3	<input type="checkbox"/> 0 0	
7 <input type="checkbox"/> 0 3	<input type="checkbox"/> 0 0	15 <input type="checkbox"/> 0 3	<input type="checkbox"/> 0 0		23 <input type="checkbox"/> 0 3	<input type="checkbox"/> 0 0	31 <input type="checkbox"/> 0 3	<input type="checkbox"/> 0 0	
8 <input type="checkbox"/> 0 3	<input type="checkbox"/> 0 0	16 <input type="checkbox"/> 0 3	<input type="checkbox"/> 0 0		24 <input type="checkbox"/> 0 3	<input type="checkbox"/> 0 0	32 <input type="checkbox"/> 0 3	<input type="checkbox"/> 0 0	

**ALARM/FIRE SUPV REPORT CODES/ID DIGITS & TRB/BYP/RESTORE CODES FOR ZONES 33-64**

*64 CODE	*65 ID	*66 CODE	*67 ID	*68	*69 CODE	*70 ID	*71 CODE	*72 ID	*73
33 <input type="checkbox"/> 0 3	<input type="checkbox"/> 0 0	41 <input type="checkbox"/> 0 3	<input type="checkbox"/> 0 0	<input type="checkbox"/> 0 9 Alm/supv rst.	49 <input type="checkbox"/> 0 1	<input type="checkbox"/> 0 0	57 <input type="checkbox"/> 0 3	<input type="checkbox"/> 0 0	<input type="checkbox"/> 0 9 Alm/supv rst.
34 <input type="checkbox"/> 0 3	<input type="checkbox"/> 0 0	42 <input type="checkbox"/> 0 3	<input type="checkbox"/> 0 0	<input type="checkbox"/> 0 5 Trouble	50 <input type="checkbox"/> 0 1	<input type="checkbox"/> 0 0	58 <input type="checkbox"/> 0 3	<input type="checkbox"/> 0 0	<input type="checkbox"/> 0 5 Trouble
35 <input type="checkbox"/> 0 3	<input type="checkbox"/> 0 0	43 <input type="checkbox"/> 0 3	<input type="checkbox"/> 0 0	<input type="checkbox"/> 0 9 Trble Rst.	51 <input type="checkbox"/> 0 1	<input type="checkbox"/> 0 0	59 <input type="checkbox"/> 0 3	<input type="checkbox"/> 0 0	<input type="checkbox"/> 0 9 Trble Rst.
36 <input type="checkbox"/> 0 3	<input type="checkbox"/> 0 0	44 <input type="checkbox"/> 0 3	<input type="checkbox"/> 0 0	<input type="checkbox"/> 0 0 Bypass	52 <input type="checkbox"/> 0 1	<input type="checkbox"/> 0 0	60 <input type="checkbox"/> 0 3	<input type="checkbox"/> 0 0	<input type="checkbox"/> 0 0 Bypass
37 <input type="checkbox"/> 0 3	<input type="checkbox"/> 0 0	45 <input type="checkbox"/> 0 3	<input type="checkbox"/> 0 0	<input type="checkbox"/> 0 0 Byppss Rst.	53 <input type="checkbox"/> 0 1	<input type="checkbox"/> 0 0	61 <input type="checkbox"/> 0 3	<input type="checkbox"/> 0 0	<input type="checkbox"/> 0 0 Byppss Rst.
38 <input type="checkbox"/> 0 3	<input type="checkbox"/> 0 0	46 <input type="checkbox"/> 0 3	<input type="checkbox"/> 0 0		54 <input type="checkbox"/> 0 1	<input type="checkbox"/> 0 0	62 <input type="checkbox"/> 0 2	<input type="checkbox"/> 0 0	
39 <input type="checkbox"/> 0 3	<input type="checkbox"/> 0 0	47 <input type="checkbox"/> 0 3	<input type="checkbox"/> 0 0		55 <input type="checkbox"/> 0 1	<input type="checkbox"/> 0 0	63 <input type="checkbox"/> 0 2	<input type="checkbox"/> 0 0	
40 <input type="checkbox"/> 0 3	<input type="checkbox"/> 0 0	48 <input type="checkbox"/> 0 1	<input type="checkbox"/> 0 0		56 <input type="checkbox"/> 0 3	<input type="checkbox"/> 0 0	64 <input type="checkbox"/> 0 3	<input type="checkbox"/> 0 0	

**ALARM/FIRE SUPV REPORT CODES/ID DIGITS & TRB/BYP/RESTORE CODES FOR ZONES 70-99**

*76 CODE	*77 ID	*78	3*40 CODE	3*41 ID	3*42
NU <input type="checkbox"/> 0 0	<input type="checkbox"/> 0 0	<input type="checkbox"/> 0 9 Alarm Rst.	70 <input type="checkbox"/> 0 3	<input type="checkbox"/> 0 0	<input type="checkbox"/> 0 9 Alarm Rst.
NU <input type="checkbox"/> 0 0	<input type="checkbox"/> 0 0	<input type="checkbox"/> 0 5 Trouble	71 <input type="checkbox"/> 0 3	<input type="checkbox"/> 0 0	<input type="checkbox"/> 0 5 Trouble
NU <input type="checkbox"/> 0 0	<input type="checkbox"/> 0 0	<input type="checkbox"/> 0 9 Trble Rst.	72 <input type="checkbox"/> 0 3	<input type="checkbox"/> 0 0	<input type="checkbox"/> 0 9 Trble Rst.
DU <input type="checkbox"/> 0 2	<input type="checkbox"/> 0 0	<input type="checkbox"/> 0 0 Bypass	73 <input type="checkbox"/> 0 3	<input type="checkbox"/> 0 0	<input type="checkbox"/> 0 0 Bypass
97 <input type="checkbox"/> 0 7	<input type="checkbox"/> 0 0	<input type="checkbox"/> 0 0 Byppss Rst.	74 <input type="checkbox"/> 0 3	<input type="checkbox"/> 0 0	<input type="checkbox"/> 0 0 Byppss Rst.
95 <input type="checkbox"/> 0 2	<input type="checkbox"/> 0 0	(1 + *) panic	75 <input type="checkbox"/> 0 3	<input type="checkbox"/> 0 0	
96 <input type="checkbox"/> 0 2	<input type="checkbox"/> 0 0	(3 + #) panic	76 <input type="checkbox"/> 0 3	<input type="checkbox"/> 0 0	
99 <input type="checkbox"/> 0 2	<input type="checkbox"/> 0 0	(* + #) panic	77 <input type="checkbox"/> 0 3	<input type="checkbox"/> 0 0	

NOTES: DU= DURESS; 97= Poll Loop Short

**SYSTEM NON ALARM CODES**

	*81 First Digit	*82 Second Digit		1*40 First Digit	1*41 Second Digit
Close	<input type="checkbox"/> 0 0	<input type="checkbox"/> 0 0	Armed STAY	<input type="checkbox"/> 0 0	<input type="checkbox"/> 0 0
Open	<input type="checkbox"/> 0 0	<input type="checkbox"/> 0 0	Time/Date set	<input type="checkbox"/> 0 0	<input type="checkbox"/> 0 0
Low Battery	<input type="checkbox"/> 0 5	<input type="checkbox"/> 0 0	Event Log 50/90%	<input type="checkbox"/> 0 0	<input type="checkbox"/> 0 0
Low Bat Res.	<input type="checkbox"/> 0 9	<input type="checkbox"/> 0 0	Event Log overflow	<input type="checkbox"/> 0 0	<input type="checkbox"/> 0 0
AC Loss	<input type="checkbox"/> 0 5	<input type="checkbox"/> 0 0			
AC Restore	<input type="checkbox"/> 0 9	<input type="checkbox"/> 0 0			
Commun. Test	<input type="checkbox"/> 1 0	<input type="checkbox"/> 0 0			
Power Up	<input type="checkbox"/> 0 0	<input type="checkbox"/> 0 0			
Cancel	<input type="checkbox"/> 0 0	<input type="checkbox"/> 0 0			
Prog. Tamper	<input type="checkbox"/> 0 0	<input type="checkbox"/> 0 0			

**ZONE TYPE RESTORE ENABLES**

*79	ZONE TYPES 1-8 All enabled							
	<input type="checkbox"/> 1	<input type="checkbox"/> 1	<input type="checkbox"/> 1	<input type="checkbox"/> 1	<input type="checkbox"/> 1	<input type="checkbox"/> 1	<input type="checkbox"/> 1	<input type="checkbox"/> 1
	1	2	3	4	5	6	7	8
*80	ZONE TYPES 9 & 10 <input type="checkbox"/> 1 <input type="checkbox"/> 1							
	All enabled 9 10							
3*50	ZONE TYPES 16-19 All enabled <input type="checkbox"/> 1 <input type="checkbox"/> 1 <input type="checkbox"/> 1 <input type="checkbox"/> 1							
	16	17	18	19				

Second digit of each code applies only to 4+2 or expanded (fields \*52 & \*53) formats.

## COMMUNICATION DEFAULTS for ADEMCO EXPRESS FORMAT (\*94\*81)

<table border="0" style="width: 100%;"> <tr> <td style="width: 30%;">*45 PRIMARY FORMAT</td> <td style="width: 10%; text-align: center;"><input type="text" value="3"/></td> <td style="width: 60%;">Ademco Express</td> </tr> <tr> <td>*46 LOW SPEED FORMAT (Primary)</td> <td style="text-align: center;"><input type="text" value="0"/></td> <td></td> </tr> <tr> <td>*47 SECONDARY FORMAT</td> <td style="text-align: center;"><input type="text" value="3"/></td> <td>Ademco Express</td> </tr> <tr> <td>*48 LOW SPEED FORMAT (Sec.)</td> <td style="text-align: center;"><input type="text" value="0"/></td> <td></td> </tr> <tr> <td>*49 CHECKSUM VERIFICATION</td> <td style="text-align: center;"><input type="text" value="0"/></td> <td style="text-align: center;"><input type="text" value="0"/></td> </tr> <tr> <td style="padding-left: 20px;">No checksum</td> <td style="text-align: center;">Primary</td> <td style="text-align: center;">Secondary</td> </tr> <tr> <td>*50 SESCOA/RADIONICS SELECT</td> <td style="text-align: center;"><input type="text" value="0"/></td> <td>Radionics</td> </tr> </table>	*45 PRIMARY FORMAT	<input type="text" value="3"/>	Ademco Express	*46 LOW SPEED FORMAT (Primary)	<input type="text" value="0"/>		*47 SECONDARY FORMAT	<input type="text" value="3"/>	Ademco Express	*48 LOW SPEED FORMAT (Sec.)	<input type="text" value="0"/>		*49 CHECKSUM VERIFICATION	<input type="text" value="0"/>	<input type="text" value="0"/>	No checksum	Primary	Secondary	*50 SESCOA/RADIONICS SELECT	<input type="text" value="0"/>	Radionics	<table border="0" style="width: 100%;"> <tr> <td style="width: 30%;">*51 DUAL REPORTING</td> <td style="width: 10%; text-align: center;"><input type="text" value="0"/></td> <td style="width: 60%;">no</td> </tr> <tr> <td>*52 STANDARD/EXPANDED REPORT FOR PRIMARY</td> <td style="text-align: center;"><input type="text" value="0"/></td> <td style="text-align: center;"><input type="text" value="0"/></td> </tr> <tr> <td style="padding-left: 20px;">Alarm Rstr Bypass Trbl Opn/Cls Low Bat</td> <td style="text-align: center;"><input type="text" value="0"/></td> <td style="text-align: center;"><input type="text" value="0"/></td> </tr> <tr> <td style="padding-left: 20px;">Fire Supv Walk Test</td> <td></td> <td style="text-align: center;">standard</td> </tr> <tr> <td>*53 STANDARD/EXPANDED REPORT FOR SECONDARY</td> <td style="text-align: center;"><input type="text" value="0"/></td> <td style="text-align: center;"><input type="text" value="0"/></td> </tr> <tr> <td style="padding-left: 20px;">Alarm Rstr Bypass Trbl Opn/Cls Low Bat</td> <td style="text-align: center;"><input type="text" value="0"/></td> <td style="text-align: center;"><input type="text" value="0"/></td> </tr> <tr> <td style="padding-left: 20px;">Fire Supv Walk Test</td> <td></td> <td style="text-align: center;">standard</td> </tr> </table>	*51 DUAL REPORTING	<input type="text" value="0"/>	no	*52 STANDARD/EXPANDED REPORT FOR PRIMARY	<input type="text" value="0"/>	<input type="text" value="0"/>	Alarm Rstr Bypass Trbl Opn/Cls Low Bat	<input type="text" value="0"/>	<input type="text" value="0"/>	Fire Supv Walk Test		standard	*53 STANDARD/EXPANDED REPORT FOR SECONDARY	<input type="text" value="0"/>	<input type="text" value="0"/>	Alarm Rstr Bypass Trbl Opn/Cls Low Bat	<input type="text" value="0"/>	<input type="text" value="0"/>	Fire Supv Walk Test		standard
*45 PRIMARY FORMAT	<input type="text" value="3"/>	Ademco Express																																									
*46 LOW SPEED FORMAT (Primary)	<input type="text" value="0"/>																																										
*47 SECONDARY FORMAT	<input type="text" value="3"/>	Ademco Express																																									
*48 LOW SPEED FORMAT (Sec.)	<input type="text" value="0"/>																																										
*49 CHECKSUM VERIFICATION	<input type="text" value="0"/>	<input type="text" value="0"/>																																									
No checksum	Primary	Secondary																																									
*50 SESCOA/RADIONICS SELECT	<input type="text" value="0"/>	Radionics																																									
*51 DUAL REPORTING	<input type="text" value="0"/>	no																																									
*52 STANDARD/EXPANDED REPORT FOR PRIMARY	<input type="text" value="0"/>	<input type="text" value="0"/>																																									
Alarm Rstr Bypass Trbl Opn/Cls Low Bat	<input type="text" value="0"/>	<input type="text" value="0"/>																																									
Fire Supv Walk Test		standard																																									
*53 STANDARD/EXPANDED REPORT FOR SECONDARY	<input type="text" value="0"/>	<input type="text" value="0"/>																																									
Alarm Rstr Bypass Trbl Opn/Cls Low Bat	<input type="text" value="0"/>	<input type="text" value="0"/>																																									
Fire Supv Walk Test		standard																																									

### ALARM/FIRE SUPV REPORT CODES/ID DIGITS & TRB/BYP/RESTORE CODES FOR ZONES 1-32

*54 CODE	*55 ID	*56 CODE	*57 ID	*58	*59 CODE	*60 ID	*61 CODE	*62 ID	*63						
1	<input type="text" value="10"/>	<input type="text" value="01"/>	9	<input type="text" value="10"/>	<input type="text" value="09"/>	14	Alm/supv rst.	17	<input type="text" value="01"/>	<input type="text" value="07"/>	25	<input type="text" value="02"/>	<input type="text" value="05"/>	14	Alm/supv rst.
2	<input type="text" value="10"/>	<input type="text" value="02"/>	10	<input type="text" value="01"/>	<input type="text" value="10"/>	15	Trouble	18	<input type="text" value="01"/>	<input type="text" value="08"/>	26	<input type="text" value="02"/>	<input type="text" value="06"/>	15	Trouble
3	<input type="text" value="10"/>	<input type="text" value="03"/>	11	<input type="text" value="01"/>	<input type="text" value="01"/>	14	Trble Rst.	19	<input type="text" value="01"/>	<input type="text" value="09"/>	27	<input type="text" value="02"/>	<input type="text" value="07"/>	14	Trble Rst.
4	<input type="text" value="10"/>	<input type="text" value="04"/>	12	<input type="text" value="01"/>	<input type="text" value="02"/>	00	Bypass	20	<input type="text" value="02"/>	<input type="text" value="10"/>	28	<input type="text" value="02"/>	<input type="text" value="08"/>	00	Bypass
5	<input type="text" value="10"/>	<input type="text" value="05"/>	13	<input type="text" value="01"/>	<input type="text" value="03"/>	00	Bypass Rst.	21	<input type="text" value="02"/>	<input type="text" value="01"/>	29	<input type="text" value="02"/>	<input type="text" value="09"/>	00	Bypass Rst.
6	<input type="text" value="10"/>	<input type="text" value="06"/>	14	<input type="text" value="01"/>	<input type="text" value="04"/>			22	<input type="text" value="02"/>	<input type="text" value="02"/>	30	<input type="text" value="03"/>	<input type="text" value="10"/>		
7	<input type="text" value="10"/>	<input type="text" value="07"/>	15	<input type="text" value="01"/>	<input type="text" value="05"/>			23	<input type="text" value="02"/>	<input type="text" value="03"/>	31	<input type="text" value="03"/>	<input type="text" value="01"/>		
8	<input type="text" value="10"/>	<input type="text" value="08"/>	16	<input type="text" value="01"/>	<input type="text" value="06"/>			24	<input type="text" value="02"/>	<input type="text" value="04"/>	32	<input type="text" value="03"/>	<input type="text" value="02"/>		

### ALARM/FIRE SUPV REPORT CODES/ID DIGITS & TRB/BYP/RESTORE CODES FOR ZONES 33-64

*64 CODE	*65 ID	*66 CODE	*67 ID	*68	*69 CODE	*70 ID	*71 CODE	*72 ID	*73						
33	<input type="text" value="03"/>	<input type="text" value="03"/>	41	<input type="text" value="04"/>	<input type="text" value="01"/>	14	Alm/supv rst.	49	<input type="text" value="04"/>	<input type="text" value="09"/>	57	<input type="text" value="05"/>	<input type="text" value="07"/>	14	Alm/supv rst.
34	<input type="text" value="03"/>	<input type="text" value="04"/>	42	<input type="text" value="04"/>	<input type="text" value="02"/>	15	Trouble	50	<input type="text" value="05"/>	<input type="text" value="10"/>	58	<input type="text" value="05"/>	<input type="text" value="08"/>	15	Trouble
35	<input type="text" value="03"/>	<input type="text" value="05"/>	43	<input type="text" value="04"/>	<input type="text" value="03"/>	14	Trble Rst.	51	<input type="text" value="05"/>	<input type="text" value="01"/>	59	<input type="text" value="05"/>	<input type="text" value="09"/>	14	Trble Rst.
36	<input type="text" value="03"/>	<input type="text" value="06"/>	44	<input type="text" value="04"/>	<input type="text" value="04"/>	00	Bypass	52	<input type="text" value="05"/>	<input type="text" value="02"/>	60	<input type="text" value="06"/>	<input type="text" value="10"/>	00	Bypass
37	<input type="text" value="03"/>	<input type="text" value="07"/>	45	<input type="text" value="04"/>	<input type="text" value="05"/>	00	Bypass Rst.	53	<input type="text" value="05"/>	<input type="text" value="03"/>	61	<input type="text" value="06"/>	<input type="text" value="01"/>	00	Bypass Rst.
38	<input type="text" value="03"/>	<input type="text" value="08"/>	46	<input type="text" value="04"/>	<input type="text" value="06"/>			54	<input type="text" value="05"/>	<input type="text" value="04"/>	62	<input type="text" value="06"/>	<input type="text" value="02"/>		
39	<input type="text" value="03"/>	<input type="text" value="09"/>	47	<input type="text" value="04"/>	<input type="text" value="07"/>			55	<input type="text" value="05"/>	<input type="text" value="05"/>	63	<input type="text" value="06"/>	<input type="text" value="03"/>		
40	<input type="text" value="04"/>	<input type="text" value="10"/>	48	<input type="text" value="04"/>	<input type="text" value="08"/>			56	<input type="text" value="05"/>	<input type="text" value="06"/>	64	<input type="text" value="06"/>	<input type="text" value="04"/>		

### ALARM/FIRE SUPV REPORT CODES/ID DIGITS & TRB/BYP/RESTORE CODES FOR ZONES 70-99

*76 CODE	*77 ID	*78	3*40 CODE	3*41 ID	3*42	NOTES: DU= DURESS; 97= Poll Loop Short		
NU	<input type="text" value="00"/>	<input type="text" value="14"/>	Alarm Rst.	70	<input type="text" value="07"/>	<input type="text" value="10"/>	<input type="text" value="14"/>	Alarm Rst.
NU	<input type="text" value="00"/>	<input type="text" value="15"/>	Trouble	71	<input type="text" value="07"/>	<input type="text" value="01"/>	<input type="text" value="15"/>	Trouble
NU	<input type="text" value="00"/>	<input type="text" value="14"/>	Trble Rst.	72	<input type="text" value="07"/>	<input type="text" value="02"/>	<input type="text" value="14"/>	Trble Rst.
DU	<input type="text" value="13"/>	<input type="text" value="00"/>	Bypass	73	<input type="text" value="07"/>	<input type="text" value="03"/>	<input type="text" value="00"/>	Bypass
97	<input type="text" value="09"/>	<input type="text" value="07"/>	Bypass Rst.	74	<input type="text" value="07"/>	<input type="text" value="04"/>	<input type="text" value="00"/>	Bypass Rst.
95	<input type="text" value="09"/>	<input type="text" value="05"/>	(1 + *) panic	75	<input type="text" value="07"/>	<input type="text" value="05"/>		
96	<input type="text" value="09"/>	<input type="text" value="06"/>	(3 + #) panic	76	<input type="text" value="07"/>	<input type="text" value="06"/>		
99	<input type="text" value="09"/>	<input type="text" value="09"/>	(* + #) panic	77	<input type="text" value="07"/>	<input type="text" value="07"/>		

### SYSTEM NON ALARM CODES

	*81 First Digit	*82 Second Digit		1*40 First Digit	1*41 Second Digit
Close	<input type="text" value="00"/>	<input type="text" value="00"/>	Armed STAY	<input type="text" value="00"/>	<input type="text" value="00"/>
Open	<input type="text" value="00"/>	<input type="text" value="00"/>	Time/Date set	<input type="text" value="00"/>	<input type="text" value="00"/>
Low Battery	<input type="text" value="15"/>	<input type="text" value="00"/>	Event Log 50/90%	<input type="text" value="00"/>	<input type="text" value="00"/>
Low Bat Res.	<input type="text" value="14"/>	<input type="text" value="00"/>	Event Log overflow	<input type="text" value="00"/>	<input type="text" value="00"/>
AC Loss	<input type="text" value="15"/>	<input type="text" value="00"/>			
AC Restore	<input type="text" value="14"/>	<input type="text" value="00"/>			
Commun. Test	<input type="text" value="10"/>	<input type="text" value="00"/>			
Power Up	<input type="text" value="00"/>	<input type="text" value="00"/>			
Cancel	<input type="text" value="00"/>	<input type="text" value="00"/>			
Prog. Tamper	<input type="text" value="00"/>	<input type="text" value="00"/>			

### ZONE TYPE RESTORE ENABLES

*79	ZONE TYPES 1-8 All enabled								
	<input type="text" value="1"/>	<input type="text" value="1"/>	<input type="text" value="1"/>	<input type="text" value="1"/>	<input type="text" value="1"/>	<input type="text" value="1"/>	<input type="text" value="1"/>	<input type="text" value="1"/>	
	1	2	3	4	5	6	7	8	
*80	ZONE TYPES 9 & 10 All enabled								
	<input type="text" value="1"/>	<input type="text" value="1"/>							<input type="text" value="1"/>
							9	10	
3*50	ZONE TYPES 16-19 All enabled								
	<input type="text" value="1"/>	<input type="text" value="1"/>	<input type="text" value="1"/>	<input type="text" value="1"/>					
	16	17	18	19					

Second digit of each code applies only to 4+2 or expanded (fields \*52 & \*53) formats.



**COMMUNICATION DEFAULTS for ADEMCO HIGH SPEED FORMAT (\*94\*82)**

*45	PRIMARY FORMAT	<input type="checkbox"/> 2	Ademco High Speed	*51	DUAL REPORTING	<input type="checkbox"/> 0	no
*46	LOW SPEED FORMAT (Primary)	<input type="checkbox"/> 0		*52	STANDARD/EXPANDED REPORT FOR PRIMARY	<input type="checkbox"/> 0	<input type="checkbox"/> 0
*47	SECONDARY FORMAT	<input type="checkbox"/> 2	Ademco High Speed	<input type="checkbox"/> 0	<input type="checkbox"/> 0	<input type="checkbox"/> 0	<input type="checkbox"/> 0
*48	LOW SPEED FORMAT (Sec.)	<input type="checkbox"/> 0		Alarm	Rstr	Bypass	Trbl
*49	CHECKSUM VERIFICATION	<input type="checkbox"/> 0	<input type="checkbox"/> 0	Fire Supv		Oprn/Cls	Low Bat
	No checksum		Primary	Secondary			Walk Test
*50	SESCO/RADIONICS SELECT	<input type="checkbox"/> 0	Radionics	*53	STANDARD/EXPANDED REPORT FOR SECONDARY	<input type="checkbox"/> 0	<input type="checkbox"/> 0
				Alarm	Rstr	Bypass	Trbl
				Fire Supv		Oprn/Cls	Low Bat
							Walk Test

**ALARM/FIRE SUPV REPORT CODES/ID DIGITS & TRB/BYP/RESTORE CODES FOR ZONES 1-32**

*54 CODE	*55 ID	*56 CODE	*57 ID	*58	*59 CODE	*60 ID	*61 CODE	*62 ID	*63						
1	<input type="checkbox"/> 0 1	<input type="checkbox"/> 0 0	9	<input type="checkbox"/> 0 3	<input type="checkbox"/> 0 0	<input type="checkbox"/> 0 1	Alm/supv rst.	17	<input type="checkbox"/> 0 4	<input type="checkbox"/> 0 0	25	<input type="checkbox"/> 0 4	<input type="checkbox"/> 0 0	<input type="checkbox"/> 0 1	Alm/supv rst.
2	<input type="checkbox"/> 0 1	<input type="checkbox"/> 0 0	10	<input type="checkbox"/> 0 3	<input type="checkbox"/> 0 0	<input type="checkbox"/> 0 1	Trouble	18	<input type="checkbox"/> 0 4	<input type="checkbox"/> 0 0	26	<input type="checkbox"/> 0 4	<input type="checkbox"/> 0 0	<input type="checkbox"/> 0 1	Trouble
3	<input type="checkbox"/> 0 2	<input type="checkbox"/> 0 0	11	<input type="checkbox"/> 0 3	<input type="checkbox"/> 0 0	<input type="checkbox"/> 0 1	Trble Rst.	19	<input type="checkbox"/> 0 4	<input type="checkbox"/> 0 0	27	<input type="checkbox"/> 0 4	<input type="checkbox"/> 0 0	<input type="checkbox"/> 0 1	Trble Rst.
4	<input type="checkbox"/> 0 2	<input type="checkbox"/> 0 0	12	<input type="checkbox"/> 0 3	<input type="checkbox"/> 0 0	<input type="checkbox"/> 0 0	Bypass	20	<input type="checkbox"/> 0 4	<input type="checkbox"/> 0 0	28	<input type="checkbox"/> 0 4	<input type="checkbox"/> 0 0	<input type="checkbox"/> 0 0	Bypass
5	<input type="checkbox"/> 0 2	<input type="checkbox"/> 0 0	13	<input type="checkbox"/> 0 3	<input type="checkbox"/> 0 0	<input type="checkbox"/> 0 0	Byps Rst.	21	<input type="checkbox"/> 0 4	<input type="checkbox"/> 0 0	29	<input type="checkbox"/> 0 4	<input type="checkbox"/> 0 0	<input type="checkbox"/> 0 0	Byps Rst.
6	<input type="checkbox"/> 0 2	<input type="checkbox"/> 0 0	14	<input type="checkbox"/> 0 3	<input type="checkbox"/> 0 0			22	<input type="checkbox"/> 0 4	<input type="checkbox"/> 0 0	30	<input type="checkbox"/> 0 4	<input type="checkbox"/> 0 0		
7	<input type="checkbox"/> 0 2	<input type="checkbox"/> 0 0	15	<input type="checkbox"/> 0 3	<input type="checkbox"/> 0 0			23	<input type="checkbox"/> 0 4	<input type="checkbox"/> 0 0	31	<input type="checkbox"/> 0 4	<input type="checkbox"/> 0 0		
8	<input type="checkbox"/> 0 2	<input type="checkbox"/> 0 0	16	<input type="checkbox"/> 0 3	<input type="checkbox"/> 0 0			24	<input type="checkbox"/> 0 4	<input type="checkbox"/> 0 0	32	<input type="checkbox"/> 0 5	<input type="checkbox"/> 0 0		

**ALARM/FIRE SUPV REPORT CODES/ID DIGITS & TRB/BYP/RESTORE CODES FOR ZONES 33-64**

*64 CODE	*65 ID	*66 CODE	*67 ID	*68	*69 CODE	*70 ID	*71 CODE	*72 ID	*73						
33	<input type="checkbox"/> 0 5	<input type="checkbox"/> 0 0	41	<input type="checkbox"/> 0 5	<input type="checkbox"/> 0 0	<input type="checkbox"/> 0 1	Alm/supv rst.	49	<input type="checkbox"/> 0 1	<input type="checkbox"/> 0 0	57	<input type="checkbox"/> 0 6	<input type="checkbox"/> 0 0	<input type="checkbox"/> 0 1	Alm/supv rst.
34	<input type="checkbox"/> 0 5	<input type="checkbox"/> 0 0	42	<input type="checkbox"/> 0 5	<input type="checkbox"/> 0 0	<input type="checkbox"/> 0 1	Trouble	50	<input type="checkbox"/> 0 1	<input type="checkbox"/> 0 0	58	<input type="checkbox"/> 0 6	<input type="checkbox"/> 0 0	<input type="checkbox"/> 0 1	Trouble
35	<input type="checkbox"/> 0 5	<input type="checkbox"/> 0 0	43	<input type="checkbox"/> 0 5	<input type="checkbox"/> 0 0	<input type="checkbox"/> 0 1	Trble Rst.	51	<input type="checkbox"/> 0 1	<input type="checkbox"/> 0 0	59	<input type="checkbox"/> 0 6	<input type="checkbox"/> 0 0	<input type="checkbox"/> 0 1	Trble Rst.
36	<input type="checkbox"/> 0 5	<input type="checkbox"/> 0 0	44	<input type="checkbox"/> 0 5	<input type="checkbox"/> 0 0	<input type="checkbox"/> 0 0	Bypass	52	<input type="checkbox"/> 0 1	<input type="checkbox"/> 0 0	60	<input type="checkbox"/> 0 6	<input type="checkbox"/> 0 0	<input type="checkbox"/> 0 0	Bypass
37	<input type="checkbox"/> 0 5	<input type="checkbox"/> 0 0	45	<input type="checkbox"/> 0 5	<input type="checkbox"/> 0 0	<input type="checkbox"/> 0 0	Byps Rst.	53	<input type="checkbox"/> 0 1	<input type="checkbox"/> 0 0	61	<input type="checkbox"/> 0 6	<input type="checkbox"/> 0 0	<input type="checkbox"/> 0 0	Byps Rst.
38	<input type="checkbox"/> 0 5	<input type="checkbox"/> 0 0	46	<input type="checkbox"/> 0 5	<input type="checkbox"/> 0 0			54	<input type="checkbox"/> 0 1	<input type="checkbox"/> 0 0	62	<input type="checkbox"/> 0 9	<input type="checkbox"/> 0 0		
39	<input type="checkbox"/> 0 5	<input type="checkbox"/> 0 0	47	<input type="checkbox"/> 0 5	<input type="checkbox"/> 0 0			55	<input type="checkbox"/> 0 1	<input type="checkbox"/> 0 0	63	<input type="checkbox"/> 0 9	<input type="checkbox"/> 0 0		
40	<input type="checkbox"/> 0 5	<input type="checkbox"/> 0 0	48	<input type="checkbox"/> 0 1	<input type="checkbox"/> 0 0			56	<input type="checkbox"/> 0 6	<input type="checkbox"/> 0 0	64	<input type="checkbox"/> 0 6	<input type="checkbox"/> 0 0		

**ALARM/FIRE SUPV REPORT CODES/ID DIGITS & TRB/BYP/RESTORE CODES FOR ZONES 70-99**

*76 CODE	*77 ID	*78	3*40 CODE	3*41 ID	3*42				
NU	<input type="checkbox"/> 0 0	<input type="checkbox"/> 0 0	<input type="checkbox"/> 0 1	Alarm Rst.	70	<input type="checkbox"/> 0 7	<input type="checkbox"/> 0 0	<input type="checkbox"/> 0 1	Alarm Rst.
NU	<input type="checkbox"/> 0 0	<input type="checkbox"/> 0 0	<input type="checkbox"/> 0 1	Trouble	71	<input type="checkbox"/> 0 7	<input type="checkbox"/> 0 0	<input type="checkbox"/> 0 1	Trouble
NU	<input type="checkbox"/> 0 0	<input type="checkbox"/> 0 0	<input type="checkbox"/> 0 1	Trble Rst.	72	<input type="checkbox"/> 0 7	<input type="checkbox"/> 0 0	<input type="checkbox"/> 0 1	Trble Rst.
DU	<input type="checkbox"/> 0 1	<input type="checkbox"/> 0 0	<input type="checkbox"/> 0 0	Bypass	73	<input type="checkbox"/> 0 7	<input type="checkbox"/> 0 0	<input type="checkbox"/> 0 0	Bypass
97	<input type="checkbox"/> 0 7	<input type="checkbox"/> 0 0	<input type="checkbox"/> 0 0	Byps Rst.	74	<input type="checkbox"/> 0 7	<input type="checkbox"/> 0 0	<input type="checkbox"/> 0 0	Byps Rst.
95	<input type="checkbox"/> 1 0	<input type="checkbox"/> 0 0	(1 + *)	panic	75	<input type="checkbox"/> 0 7	<input type="checkbox"/> 0 0		
96	<input type="checkbox"/> 1 1	<input type="checkbox"/> 0 0	(3 + #)	panic	76	<input type="checkbox"/> 0 7	<input type="checkbox"/> 0 0		
99	<input type="checkbox"/> 1 2	<input type="checkbox"/> 0 0	(* + #)	panic	77	<input type="checkbox"/> 0 7	<input type="checkbox"/> 0 0		

NOTES: DU= DURESS; 97= Poll Loop Short

**SYSTEM NON ALARM CODES**

	*81	*82		1*40	1*41
	First Digit	Second Digit		First Digit	Second Digit
Close	<input type="checkbox"/> 0 0	<input type="checkbox"/> 0 0	Armed STAY	<input type="checkbox"/> 0 0	<input type="checkbox"/> 0 0
Open	<input type="checkbox"/> 0 0	<input type="checkbox"/> 0 0	Time/Date set	<input type="checkbox"/> 0 0	<input type="checkbox"/> 0 0
Low Battery	<input type="checkbox"/> 0 1	<input type="checkbox"/> 0 0	Event Log 50/90%	<input type="checkbox"/> 0 0	<input type="checkbox"/> 0 0
Low Bat Res.	<input type="checkbox"/> 0 1	<input type="checkbox"/> 0 0	Event Log overflow	<input type="checkbox"/> 0 0	<input type="checkbox"/> 0 0
AC Loss	<input type="checkbox"/> 0 1	<input type="checkbox"/> 0 0			
AC Restore	<input type="checkbox"/> 0 1	<input type="checkbox"/> 0 0			
Commun. Test	<input type="checkbox"/> 0 1	<input type="checkbox"/> 0 0			
Power Up	<input type="checkbox"/> 0 0	<input type="checkbox"/> 0 0			
Cancel	<input type="checkbox"/> 0 0	<input type="checkbox"/> 0 0			
Prog. Tamper	<input type="checkbox"/> 0 0	<input type="checkbox"/> 0 0			

**ZONE TYPE RESTORE ENABLES**

*79	ZONE TYPES 1-8 All enabled	<input type="checkbox"/> 1	<input type="checkbox"/> 1	<input type="checkbox"/> 1	<input type="checkbox"/> 1	<input type="checkbox"/> 1	<input type="checkbox"/> 1	<input type="checkbox"/> 1	<input type="checkbox"/> 1
		1	2	3	4	5	6	7	8
*80	ZONE TYPES 9 & 10 All enabled	<input type="checkbox"/> 1	<input type="checkbox"/> 1						
		9	10						
3*50	ZONE TYPES 16-19 All enabled	<input type="checkbox"/> 1	<input type="checkbox"/> 1	<input type="checkbox"/> 1	<input type="checkbox"/> 1				
		16	17	18	19				

Second digit of each code applies only to 4+2 or expanded (fields \*52 & \*53) formats.

## COMMUNICATION DEFAULTS for ADEMCO's CONTACT ID FORMAT (\*94\*83)

- |  |   |
|--|---|
| <p>*45 PRIMARY FORMAT <input type="checkbox"/> Ademco Contact ID <input checked="" type="checkbox"/></p> <p>*46 LOW SPEED FORMAT (Primary) <input type="checkbox"/></p> <p>*47 SECONDARY FORMAT <input checked="" type="checkbox"/> Ademco Contact ID</p> <p>*48 LOW SPEED FORMAT (Sec.) <input type="checkbox"/></p> <p>*49 CHECKSUM VERIFICATION<br/>No checksum <input type="checkbox"/> <input type="checkbox"/><br/>Primary Secondary</p> <p>*50 SESCOA/RADIONICS SELECT <input type="checkbox"/> Radionics</p> | <p>*51 DUAL REPORTING <input type="checkbox"/> no</p> <p>*52 STANDARD/EXPANDED REPORT FOR PRIMARY<br/><input type="checkbox"/> <input type="checkbox"/> <input type="checkbox"/> <input type="checkbox"/> <input type="checkbox"/> <input type="checkbox"/> standard<br/>Alarm Rstr Bypass Trbl Oprv/Cls Low Bat<br/>Fire Supv Walk Test</p> <p>*53 STANDARD/EXPANDED REPORT FOR SECONDARY<br/><input type="checkbox"/> <input type="checkbox"/> <input type="checkbox"/> <input type="checkbox"/> <input type="checkbox"/> <input type="checkbox"/> standard<br/>Alarm Rstr Bypass Trbl Oprv/Cls Low Bat<br/>Fire Supv Walk Test</p> |
|--|---|

### ALARM/FIRE SUPV REPORT CODES/ID DIGITS & TRB/BYP/RESTORE CODES FOR ZONES 1-32

*54 CODE	*55 ID	*56 CODE	*57 ID	*58	*59 CODE	*60 ID	*61 CODE	*62 ID	*63						
1	0 1	0 0	9	0 9	0 0	0 1	Alm/supv rst.	17	0 2	0 0	25	1 0	0 0	0 1	Alm/supv rst.
2	0 2	0 0	10	1 0	0 0	0 1	Trouble	18	0 3	0 0	26	1 1	0 0	0 1	Trouble
3	0 3	0 0	11	1 1	0 0	0 1	Trble Rst.	19	0 4	0 0	27	1 2	0 0	0 1	Trble Rst.
4	0 4	0 0	12	1 2	0 0	0 0	Bypass	20	0 5	0 0	28	1 3	0 0	0 0	Bypass
5	0 5	0 0	13	1 3	0 0	0 0	Bypass Rst.	21	0 6	0 0	29	1 4	0 0	0 0	Bypass Rst.
6	0 6	0 0	14	1 4	0 0			22	0 7	0 0	30	1 5	0 0		
7	0 7	0 0	15	1 5	0 0			23	0 8	0 0	31	0 1	0 0		
8	0 8	0 0	16	0 1	0 0			24	0 9	0 0	32	0 2	0 0		

### ALARM/FIRE SUPV REPORT CODES/ID DIGITS & TRB/BYP/RESTORE CODES FOR ZONES 33-64

*64 CODE	*65 ID	*66 CODE	*67 ID	*68	*69 CODE	*70 ID	*71 CODE	*72 ID	*73						
33	0 3	0 0	41	1 1	0 0	0 1	Alm/supv rst.	49	0 4	0 0	57	1 2	0 0	0 1	Alm/supv rst.
34	0 4	0 0	42	1 2	0 0	0 1	Trouble	50	0 5	0 0	58	1 3	0 0	0 1	Trouble
35	0 5	0 0	43	1 3	0 0	0 1	Trble Rst.	51	0 6	0 0	59	1 4	0 0	0 1	Trble Rst.
36	0 6	0 0	44	1 4	0 0	0 0	Bypass	52	0 7	0 0	60	1 5	0 0	0 0	Bypass
37	0 7	0 0	45	1 5	0 0	0 0	Bypass Rst.	53	0 8	0 0	61	0 1	0 0	0 0	Bypass Rst.
38	0 8	0 0	46	0 1	0 0			54	0 9	0 0	62	0 2	0 0		
39	0 9	0 0	47	0 2	0 0			55	1 0	0 0	63	0 3	0 0		
40	1 0	0 0	48	0 3	0 0			56	1 1	0 0	64	0 4	0 0		

### ALARM/FIRE SUPV REPORT CODES/ID DIGITS & TRB/BYP/RESTORE CODES FOR ZONES 70-99

*76 CODE	*77 ID	*78	3*40 CODE	3*41 ID	3*42	NOTES: DU= DURESS; 97= Poll Loop Short			
NU	0 0	0 0	0 1	Alarm Rst.	70	1 0	0 0	0 1	Alarm Rst.
NU	0 0	0 0	0 1	Trouble	71	0 1	0 0	0 1	Trouble
NU	0 0	0 0	0 1	Trble Rst.	72	0 2	0 0	0 1	Trble Rst.
DU	0 2	0 0	0 0	Bypass	73	0 3	0 0	0 0	Bypass
97	0 3	0 0	0 0	Bypass Rst.	74	0 4	0 0	0 0	Bypass Rst.
95	0 4	0 0		(1 + #) panic	75	0 5	0 0		
96	0 5	0 0		(3 + #) panic	76	0 6	0 0		
99	0 6	0 0		(* + #) panic	77	0 7	0 0		

### SYSTEM NON ALARM CODES

	*81 First Digit	*82 Second Digit
Close	0 0	0 0
Open	0 0	0 0
Low Battery	0 1	0 0
Low Bat Res.	0 1	0 0
AC Loss	0 1	0 0
AC Restore	0 1	0 0
Commun. Test	0 1	0 0
Power Up	0 0	0 0
Cancel	0 0	0 0
Prog. Tamper	0 0	0 0

	1*40 First Digit	1*41 Second Digit
Armed STAY	0 0	0 0
Time/Date set	0 0	0 0
Event Log 50/90%	0 0	0 0
Event Log overflow	0 0	0 0

	3*51 First Digit	3*52 Second Digit
Walk Test Start	0 0	0 0
Walk Test End	0 0	0 0

### ZONE TYPE RESTORE ENABLES

\*79 ZONE TYPES 1-8 All enabled

1	1	1	1	1	1	1	1
1	2	3	4	5	6	7	8

\*80 ZONE TYPES 9 & 10 All enabled

1	1
9	10

3\*50 ZONE TYPES 16-19 All enabled

1	1	1	1
16	17	18	19

Second digit of each code applies only to 4+2 or expanded (fields \*52 & \*53) formats.

## XI. SPECIFICATIONS

### 5140XM CONTROL

**Physical:** 18"H X 14.5"W X 4.3"D

**Electrical:**

Primary Power: From Ademco No. 1451 Transformer with enclosure; rated 18VAC, 72VA

Backup Battery: 12VDC, 12AH min to 34.4AH max lead acid battery (gel type)

Alarm Power: 12VDC, 2.3 amps max

Aux. Standby Power: 12VDC, 1 amp max

Total Power: Combined auxiliary standby and alarm currents must not exceed 2.3 amps

Standby Time: 24 hours with 1 amp standby load using 34.4AH battery

Fusing: Battery input, auxiliary and bell power outputs are protected using PTC circuit protectors. All outputs are power limited

**Main Dialer:**

Line Seize: Double Pole

Ringer Equivalence: 0.7B

FCC Registration: AC398U-68192-AL-E

TLM Threshold: Good line when tip to ring voltage greater than approx. 25V (13V when blue jumper cut) or when handset current greater than approx. 10mA. Bad line when both voltage and current below these levels.

Formats: Ademco Low Speed, Ademco 4+2 Express, Ademco High Speed, Ademco Contact ID, SESCOA and Radionics

**Agency Listings:**

Burglary: UL609 Grade A Local Mercantile Premises and Mercantile Safe and Vault  
UL611/UL1610 Grades A, AA Central Station

UL365 Grades A, AA Police Connect

Fire: UL864-NFPA 72 Local, NFPA71 Central Station

### 5137AD (Gray Bezel)/5137ADR (Red Bezel) REMOTE CONSOLES

**Physical:** 4.75"H X 8.4"W X 1.1"D

**Wiring:** Red: 12VDC, 90mA input power

Black: Ground

Green: Data In

Yellow: Data Out

### 5140DLM BACKUP DIALER MODULE

**Physical:** 2.75"H X 4"W X 1"D

Mounts on 5140XM main PC board shield using standoffs supplied

**Misc.:** Connects to 5140XM main PC board J3 header using ribbon cable supplied.

FCC Registration: AC398U-62668-MO-N

See 5140XM Main Dialer listing for remaining specifications

### 5140LED ANNUNCIATOR MODULE

**Physical:** 4.5"H X 2.75"W X 1.5"D

Mounts to single gang electrical box

**Indicators:** AC Power, Comm Failure, Dialer 1 Fault and Dialer 2 Fault.

Connect indicator inputs to 5140XM trigger outputs (J2 header)

**WARNING: OWNER'S INSTRUCTION NOTICE NOT TO BE REMOVED**  
REFER TO INSTRUCTIONS N6019 FOR ADDITIONAL INFORMATION

**WARNING:**  
THIS UNIT MAY BE PROGRAMMED TO INCLUDE AN ALARM VERIFICATION FEATURE THAT WILL RESULT IN A DELAY OF THE SYSTEM ALARM SIGNAL FROM THE INDICATED FIRE CIRCUITS. THE TOTAL DELAY (CONTROL UNIT PLUS SMOKE DETECTORS) SHALL NOT EXCEED 60 SECONDS. NO OTHER INITIATING DEVICES SHALL BE CONNECTED TO THESE CIRCUITS UNLESS APPROVED BY THE LOCAL AUTHORITY HAVING JURISDICTION.

CIRCUIT (ZONE)	CONTROL UNIT DELAY-SEC	SMOKE DETECTOR MODEL	DELAY-SEC

THE DELAY TIME MARKED ON THE INSTALLED DETECTOR(S) IS TO BE USED

This equipment should be installed in accordance with the National Fire Protection Association's Standard 71 and 72A (National Fire Protection Assoc., Batterymarch Park, Quincy, MA. 02269). Printed information describing proper installation, operation, and repair service is to be provided with this equipment.



**BATTERY TABS**  
BLK - RED

Connect to 12V, 12Ah min/34 AAh max lead acid batteries using cables supplied. See instructions for required capacity. Float charging voltage: 13.7VDC. Battery normally need not be replaced for at least 3 yrs.

**TEST BURGLARY SYSTEM WEEKLY**

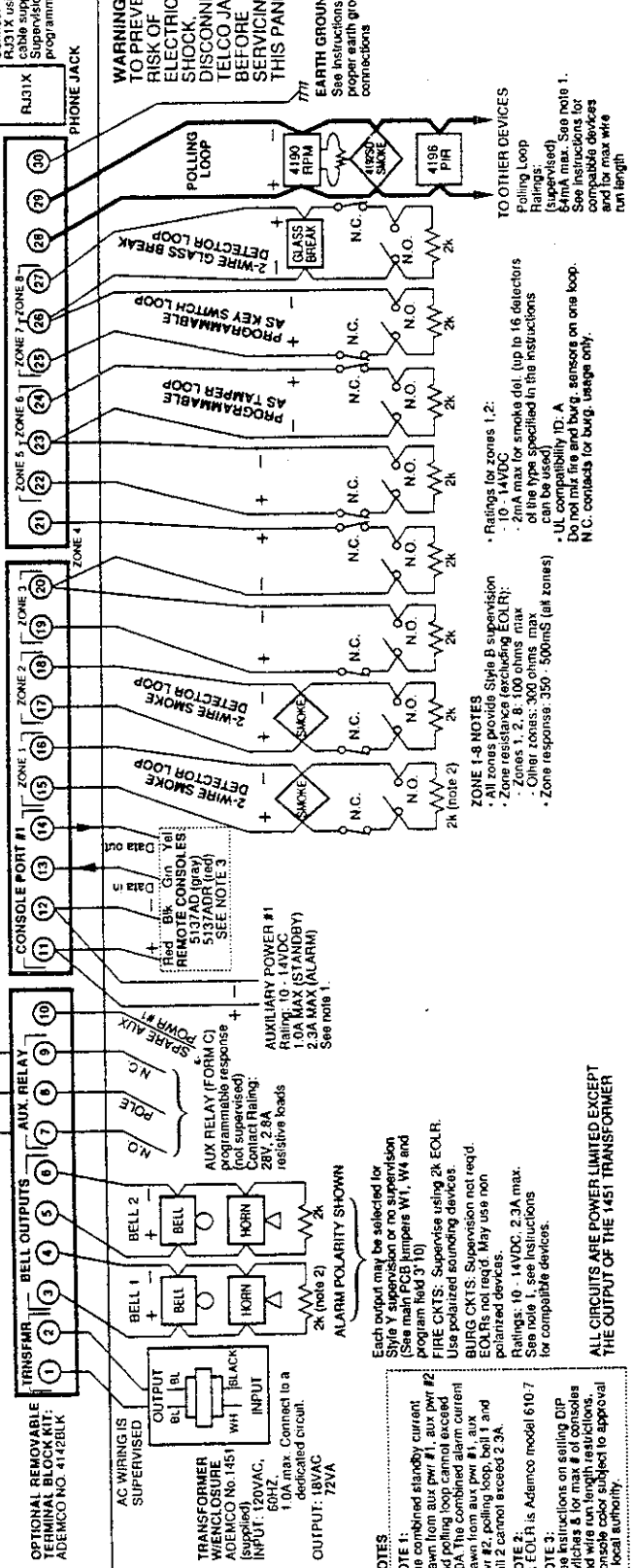
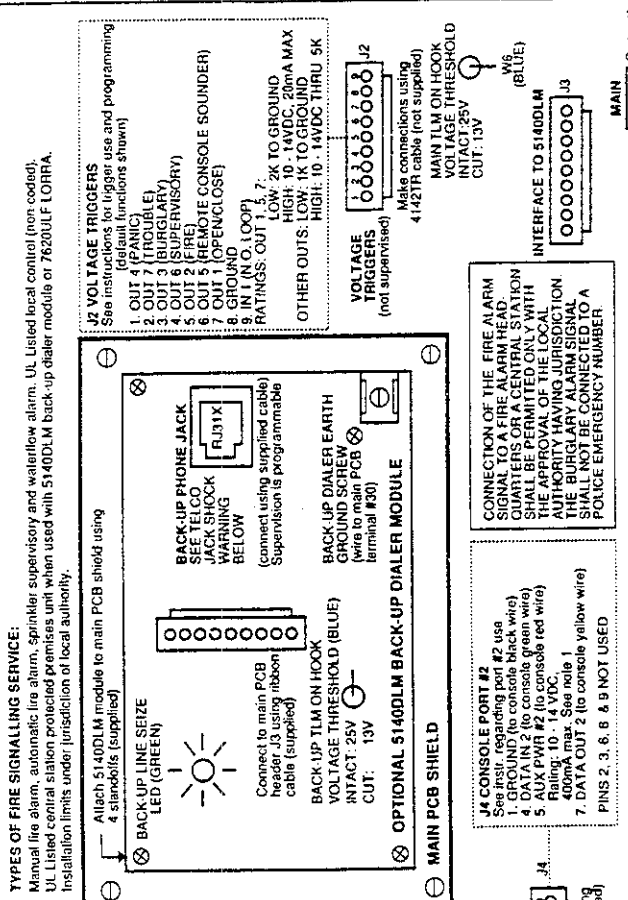

### "FEDERAL COMMUNICATIONS COMMISSION (FCC) STATEMENT"

This equipment has been tested to FCC requirements and has been found acceptable for use. The FCC requires the following statement for your information:

This equipment generates and uses radio frequency energy and if not installed and used properly, that is, in strict accordance with the manufacturer's instructions, may cause interference to radio and television reception. It has been type tested and found to comply with the limits for a Class B computing device in accordance with the specifications in Part 15 of FCC Rules, which are designed to provide reasonable protection against such interference in a residential installation. However, there is no guarantee that interference will not occur in a particular installation. If this equipment does cause interference to radio or television reception, which can be determined by turning the equipment off and on, the user is encouraged to try to correct the interference by one or more of the following measures:

- If using an indoor antenna, have a quality outdoor antenna installed.
- Reorient the receiving antenna until interference is reduced or eliminated.
- Move the receiver away from the control/communicator.
- Move the antenna leads away from any wire runs to the control/communicator.
- Plug the control/communicator into a different outlet so that it and the receiver are on different branch circuits.

If necessary, the user should consult the dealer or an experienced radio/television technician for additional suggestions.

The user or installer may find the following booklet prepared by the Federal Communications Commission helpful:

#### "Interference Handbook"

This booklet is available from the U.S. Government Printing Office, Washington, DC 20402.

The user shall not make any changes or modifications to the equipment unless authorized by the Installation Instructions or User's Manual. Unauthorized changes or modifications could void the user's authority to operate the equipment.

### IN THE EVENT OF TELEPHONE OPERATIONAL PROBLEMS

In the event of telephone operational problems, disconnect the control panel by removing the plug from the RJ31X (CA38A in Canada) wall jack. We recommend that you demonstrate disconnecting the phones on installation of the system. Do not disconnect the phone connection inside the Control Panel. Doing so will result in the loss of your phone lines. If the regular phone works correctly after the Control Panel has been disconnected from the phone lines, the Control Panel has a problem and should be returned for repair. If upon disconnection of the Control Panel, there is still a problem on the line, notify the telephone company that they have a problem and request prompt repair service. The user may not under any circumstances (in or out of warranty) attempt any service or repairs to the system. It must be returned to the factory or an authorized service agency for all repairs.

### FCC PART 68 NOTICE

This equipment complies with Part 68 of the FCC rules. On the front cover of this equipment is a label that contains, among other information, the FCC registration number and ringer equivalence number (REN) for this equipment. If requested, this information must be provided to the telephone company.

This equipment uses the following jacks:

An RJ31X is used to connect this equipment to the telephone network.

The REN is used to determine the quantity of devices which may be connected to the telephone line. Excessive RENs on the telephone line may result in the devices not ringing in response to an incoming call. In most, but not all areas, the sum of the RENs should not exceed five (5.0). To be certain of the number of devices that may be connected to the line, as determined by the total RENs, contact the telephone company to determine the maximum REN for the calling area.

If this equipment causes harm to the telephone network, the telephone company will notify you in advance that temporary discontinuance of service may be required. If advance notice is not practical, the telephone company will notify the customer as soon as possible. Also, you will be advised of your right to file a complaint with the FCC if you believe necessary.

The telephone company may make changes in its facilities, equipment, operations, or procedures that could affect the operation of the equipment. If this happens, the telephone company will provide advance notice in order for you to make the necessary modifications in order to maintain uninterrupted service.

If trouble is experienced with this equipment, please contact the manufacturer for repair and warranty information. If the trouble is causing harm to the telephone network, the telephone company may request you remove the equipment from the network until the problem is resolved.

There are no user serviceable components in this product, and all necessary repairs must be made by the manufacturer. Other repair methods may invalidate the FCC registration on this product.

This equipment cannot be used on telephone company-provided coin service. Connection to Party Line Service is subject to state tariffs.

This equipment is hearing-aid compatible.

When programming or making test calls to an emergency number, briefly explain to the dispatcher the reason for the call. Perform such activities in the off-peak hours; such as early morning or late evening.

## CANADIAN DEPARTMENT OF COMMUNICATIONS (DOC) STATEMENT

### NOTICE

The Canadian Department of Communications label identifies certified equipment. This certification means that the equipment meets certain telecommunications network protective, operational and safety requirements. The Department does not guarantee the equipment will operate to the user's satisfaction.

Before installing this equipment, users should ensure that it is permissible to be connected to the facilities of the local telecommunications company. The equipment must also be installed using an acceptable method of connection. In some cases, the company's inside wiring associated with a single line individual service may be extended by means of certified connector assembly (telephone extension cord). The customer should be aware that compliance with the above conditions may not prevent degradation of service in some situations.

Repairs to certified equipment should be made by an authorized Canadian maintenance facility designated by the supplier. Any repairs or alterations made by the user to this equipment, or equipment malfunctions, may give the telecommunications company cause to request the user to disconnect the equipment.

Users should ensure for their own protection that the electrical ground connections of the power utility, telephone lines and internal metallic water pipe system, if present, are connected together. This precaution may be particularly important in rural areas.

**Caution:** User should not attempt to make such connections themselves, but should contact the appropriate electric inspection authority, or electrician, as appropriate.

The Load Number (LN) assigned to each terminal device denotes the percentage of the total load to be connected to a telephone loop which is used by the device, to prevent overloading. The termination on a loop may consist of any combination of devices subject only to the requirement that the total of the Load Numbers of all the devices does not exceed 100.

### AVIS

L'étiquette du ministère des Communications du Canada identifie le matériel homologué. Cette étiquette certifie que le matériel est conforme à certaines normes de protection, d'exploitation et de sécurité des réseaux de télécommunications. Le ministère n'assure toutefois pas que le matériel fonctionnera à la satisfaction de l'utilisateur.

Avant d'installer ce matériel, l'utilisateur doit s'assurer qu'il est permis de le raccorder aux installations de l'entreprise locale de télécommunications. Le matériel doit également être installé en suivant une méthode acceptée de raccordement. Dans certains cas, les fils intérieurs de l'entreprise utilisés pour un service individuel à la ligne unique peuvent être prolongés au moyen d'un dispositif homologué de raccordement (cordon prolongateur téléphonique interne). L'abonné ne doit pas oublier qu'il est possible que la conformité aux conditions énoncées ci-dessus n'empêche pas la dégradation du service dans certaines situations. Actuellement, les entreprises de télécommunications ne permettent pas que l'on raccorde leur matériel aux prises d'abonnés, sauf dans les cas précis prévus par les tarifs particuliers de ces entreprises.

Les réparations du matériel homologué doivent être effectuées par un centre d'entretien canadien autorisé désigné par le fournisseur. La compagnie de télécommunications peut demander à l'utilisateur de débrancher un appareil à la suite de réparations ou de modifications effectuées par l'utilisateur ou à cause de mauvais fonctionnement.

Pour sa propre protection, l'utilisateur doit s'assurer que tous les fils de mise en terre de la source d'énergie électrique, des lignes téléphoniques de réseau de conduites d'eau s'il y en a, soient raccordés ensemble. Cette précaution est particulièrement importante dans les régions rurales.

**Avertissement:** L'utilisateur ne doit pas tenter de faire ces raccordements lui-même; il doit avoir recours à un service d'inspection des installations électriques, ou à un électricien, selon le cas.

L'indice de charge (IC) assigné à chaque dispositif terminal pour éviter toute surcharge indique le pourcentage de la charge totale qui peut être raccordé à un circuit téléphonique bouclé utilisé par ce dispositif. La terminaison du circuit bouclé peut être constituée de n'importe quelle combinaison de dispositifs, pourvu que la somme des indices de charge de l'ensemble des dispositifs ne dépasse pas 100.

**WARNING!**  
**THE LIMITATIONS OF THIS ALARM SYSTEM**

While this System is an advanced design security system, it does not offer guaranteed protection against burglary, fire or other emergency. Any alarm system, whether commercial or residential, is subject to compromise or failure to warn for a variety of reasons. For example:

- Intruders may gain access through unprotected openings or have the technical sophistication to bypass an alarm sensor or disconnect an alarm warning device.
- Intrusion detectors (e.g., passive infrared detectors), smoke detectors, and many other sensing devices will not work without power. Battery-operated devices will not work without batteries, with dead batteries, or if the batteries are not put in properly. Devices powered solely by AC will not work if their AC power supply is cut off for any reason, however briefly.
- Signals sent by wireless transmitters may be blocked or reflected by metal before they reach the alarm receiver. Even if the signal path has been recently checked during a weekly test, blockage can occur if a metal object is moved into the path.
- A user may not be able to reach a panic or emergency button quickly enough.
- While smoke detectors have played a key role in reducing residential fire deaths in the United States, they may not activate or provide early warning for a variety of reasons in as many as 35% of all fires, according to data published by the Federal Emergency Management Agency. Some of the reasons smoke detectors used in conjunction with this System may not work are as follows. Smoke detectors may have been improperly installed and positioned. Smoke detectors may not sense fires that start where smoke cannot reach the detectors, such as in chimneys, in walls, or roofs, or on the other side of closed doors. Smoke detectors also may not sense a fire on another level of a residence or building. A second floor detector, for example, may not sense a first floor or basement fire. Finally, smoke detectors have sensing limitations. No smoke detector can sense every kind of fire every time. In general, detectors may not always warn about fires caused by carelessness and safety hazards like smoking in bed, violent explosions, escaping gas, improper storage of flammable materials, overloaded electrical circuits, children playing with matches, or arson. Depending on the nature of the fire and/or location of the smoke detectors, the detector, even if it operates as anticipated, may not provide sufficient warning to allow all occupants to escape in time to prevent injury or death.
- Passive Infrared Motion Detectors can only detect intrusion within the designed ranges as diagrammed in the installation manual. Passive Infrared Detectors do not provide volumetric area protection. They do create multiple beams of protection, and intrusion can only be detected in unobstructed areas covered by the beams. They cannot detect motion or intrusion that takes place behind walls, ceilings, floors, closed doors, glass partitions, glass doors, or windows. Mechanical tampering, masking, painting or spraying of any material on the mirrors, windows or any part of the optical system can reduce their detection ability. Passive Infrared Detectors sense changes in temperature; however, as the ambient temperature of the protected area approaches the temperature range of 90° to 105°F (32° to 40°C), the detection performance can decrease.
- Alarm warning devices such as sirens, bells or horns may not alert people or wake up sleepers if they are located on the other side of closed or partly open doors. If warning devices are located on a different level of the residence from the bedrooms, then they are less likely to waken or alert people inside the bedrooms. Even persons who are awake may not hear the warning if the alarm is muffled by noise from a stereo, radio, air conditioner or other appliance, or by passing traffic. Finally, alarm warning devices, however loud, may not warn hearing-impaired people.
- Telephone lines needed to transmit alarm signals from a premises to a central monitoring station may be out of service or temporarily out of service. Telephone lines are also subject to compromise by sophisticated intruders.
- Even if the system responds to the emergency as intended, however, occupants may have insufficient time to protect themselves from the emergency situation. In the case of a monitored alarm system, authorities may not respond appropriately.
- This equipment, like other electrical devices, is subject to component failure. Even though this equipment is designed to last as long as 20 years, the electronic components could fail at any time.

The most common cause of an alarm system not functioning when an intrusion or fire occurs is inadequate maintenance. This alarm system should be tested weekly to make sure all sensors are working properly. The security console (and remote keypad) should be tested as well.

Installing an alarm system may make the owner eligible for a lower insurance rate, but an alarm system is not a substitute for insurance. Homeowners, property owners and renters should continue to act prudently in protecting themselves and continue to insure their lives and property.

We continue to develop new and improved protection devices. Users of alarm systems owe it to themselves and their loved ones to learn about these developments.

#### **ADEMCO LIMITED WARRANTY**

Alarm Device Manufacturing Company, a Division of Pittway Corporation, and its divisions, subsidiaries and affiliates ("Seller"), 165 Eileen Way, Syosset, New York 11791, warrants its products to be in conformance with its own plans and specifications and to be free from defects in materials and workmanship under normal use and service for 18 months from the date stamp control on the product or, for products not having an Ademco date stamp, for 12 months from date of original purchase unless the installation instructions or catalog sets forth a shorter period, in which case the shorter period shall apply. Seller's obligation shall be limited to repairing or replacing, at its option, free of charge for materials or labor, any product which is proved not in compliance with Seller's specifications or proves defective in materials or workmanship under normal use and service. Seller shall have no obligation under this Limited Warranty or otherwise if the product is altered or improperly repaired or serviced by anyone other than Ademco factory service. For warranty service, return product transportation prepaid, to Ademco Factory Service, 165 Eileen Way, Syosset, New York 11791.

THERE ARE NO WARRANTIES, EXPRESS OR IMPLIED, OF MERCHANTABILITY, OR FITNESS FOR A PARTICULAR PURPOSE OR OTHERWISE, WHICH EXTEND BEYOND THE DESCRIPTION ON THE FACE HEREOF. IN NO CASE SHALL SELLER BE LIABLE TO ANYONE FOR ANY CONSEQUENTIAL OR INCIDENTAL DAMAGES FOR BREACH OF THIS OR ANY OTHER WARRANTY, EXPRESS OR IMPLIED, OR UPON ANY OTHER BASIS OF LIABILITY WHATSOEVER, EVEN IF THE LOSS OR DAMAGE IS CAUSED BY THE SELLER'S OWN NEGLIGENCE OR FAULT.

Seller does not represent that the products it sells may not be compromised or circumvented; that the products will prevent any personal injury or property loss by burglary, robbery, fire or otherwise; or that the products will in all cases provide adequate warning or protection. Customer understands that a properly installed and maintained alarm may only reduce the risk of a burglary, robbery, fire or other events occurring without providing an alarm, but it is not insurance or a guarantee that such will not occur or that there will be no personal injury or property loss as a result. CONSEQUENTLY, SELLER SHALL HAVE NO LIABILITY FOR ANY PERSONAL INJURY, PROPERTY DAMAGE OR OTHER LOSS BASED ON A CLAIM THE PRODUCT FAILED TO GIVE WARNING. HOWEVER, IF SELLER IS HELD LIABLE, WHETHER DIRECTLY OR INDIRECTLY, FOR ANY LOSS OR DAMAGE ARISING UNDER THIS LIMITED WARRANTY OR OTHERWISE, REGARDLESS OF CAUSE OR ORIGIN, SELLER'S MAXIMUM LIABILITY SHALL NOT IN ANY CASE EXCEED THE PURCHASE PRICE OF THE PRODUCT, WHICH SHALL BE THE COMPLETE AND EXCLUSIVE REMEDY AGAINST SELLER. This warranty replaces any previous warranties and is the only warranty made by Seller on this product. No increase or alteration, written or verbal, of the obligations of this Limited Warranty is authorized.





N6019V1 6/93

**ALARM DEVICE MANUFACTURING CO.**  
A DIVISION OF PITTHWAY CORP.  
165 EILEEN WAY, SYOSSET, NY 11791

COPYRIGHT © 1992 PITTHWAY CORPORATION

**ADDENDUM TO:** INSTALLATION INSTRUCTIONS FOR 5140XM CONTROL  
USE WITH ISSUE: N6019V1

**RE:** Feature Changes and New Program Fields

This addendum applies to 5140XM Controls which are shipped with firmware EPROM marked:

**WA5140XM-XX** (where XX = 18 or higher)

The EPROM is located beneath the main PC board shield cover.

The following features are new for the 5140XM Control.

1. **In accordance with revisions to UL864, Standard for Commercial Fire Alarms**, the following system changes have been made.

**Silencing Console Sounds for Fire Supervisory Zone Type now requires security code + OFF**

To silence console sounds triggered by supervisory conditions on zones programmed for fire zone supervisory response (zone response type 18), you must enter the security code + OFF. Prior to this change, these console sounds could be silenced by pressing any key (no security code was needed).

**Keyswitch Mode 2 Operation (field \*15)**

New fire or burglary alarm conditions occurring after a previous alarm was silenced using the keyswitch will now automatically re-activate the corresponding fire or burglary alarm bell circuits when keyswitch mode 2 operation is selected (field \*15 set to 2). Prior to this change, alarm bell circuits remained silenced until the security code + OFF was entered at a console.

Note that when keyswitch mode 2 operation is selected, operating the keyswitch will silence fire and burglary alarms only when a fire alarm condition is present (in accordance with the existing Installation Instructions).

**OFF-NORMAL Communicator Test Report (new program fields 3\*53, 3\*54)**

Off-normal conditions are fire alarm system related conditions existing at the time a normal test report is sent. These conditions include fire alarms, fire troubles or supervisories, and certain system troubles such as earth ground faults, AC failure, low system battery, or bell circuit faults. The 5140XM now transmits an "off-normal" communicator test report (programmed in field 3\*53, 3\*54) **instead of** the normal communicator test report (programmed in fields \*81, \*82) when fire alarm system off-normal conditions are present at the time of test report transmission.

As shipped, both reports are disabled and must be enabled for installations that provide fire alarm central station service. The normal communicator test report is enabled as described in the Installation Instructions. The off-normal communicator test report is enabled as follows:

**Field 3\*53**

First Digit

**Field 3\*54**

Second Digit

For Ademco High Speed and Ademco Contact ID report formats: Enter "01" in field 3\*53.

Ademco High Speed off-normal test reports use channel 3 =1 and status channel = 9

Contact ID sends code 608.

For Low Speed Formats: Enter the first (event code) digit of the report in field 3\*53 and the second (zone number) digit of the report in field 3\*54. These fields require that two numbers be entered for each digit of the report (i.e. enter 00 if no digit is to be sent, enter 01 for "1", enter 10 for "A"... , enter 15 for "F").

Note: fields 3\*53 and 3\*54 can also be programmed by loading one of the four built-in communication defaults as follows:

Communicator Default	3*53 Value	3*54 Value
Low Speed (*94*80)	05	00
Ademco Express (*94*81)	15	00
Ademco High Speed (*94*82)	01	00
Ademco Contact ID (*94*83)	01	00

2. **Fire Supervisory Response On Short Circuit Or Open Circuit Selection (new program field 3\*13)**

Field 3\*13 allows the installer to select whether a short circuit or open circuit fault will initiate a supervisory response on zones programmed for fire supervisory response (response type 18).

3\*13  0 = trouble on open / supervisory on short;  
1 = supervisory on open / supervisory on short

When field 3\*13 is set to "0" (default), zones programmed for fire supervisory response provide trouble on open / supervisory on short. When field 3\*13 is set to "1", zones programmed for fire supervisory response provide supervisory on open / supervisory on short response.

3. **Extended waterflow and fire supervisory delay (new program field 3\*18)**

Field 3\*18 allows the fire waterflow (response type 17) and fire supervisory (response type 18) zone delay programmed in field 3\*16 to be extended.

3\*18  0 = no extended delay; 1 = delay in 3\*16 times 4

When field 3\*18 is set to "0" (default), the delay programmed in field 3\*16 applies. When field 3\*18 is set to "1" the delay programmed in field 3\*16 is multiplied by 4 (allowing delays up to 120 seconds).

4. **Manual/Automatic fire Waterflow alarm silencing (new program field 3\*14)**

Field 3\*14 allows the installer to select whether zones programmed for fire waterflow response (response type 17) can be silenced manually (security code + OFF) or can be silenced automatically when waterflow ceases.

3\*14  0 = manual silencing only; 1 = automatic silence when waterflow ceases

When field 3\*14 is set to "0" (default), waterflow zones can be silenced manually only, by entering the security code + OFF. When field 3\*14 is set to "1", waterflow zones will silence automatically when waterflow ceases (provided that no other fire alarms are present).

Note that if field 3\*14 is set for "1", entering security + OFF will not silence waterflow alarms while water continues to flow.

5. **Clarification of Duress Trigger Operation**

The Installation Instructions currently state that the silent panic/duress trigger goes HIGH when a silent panic or duress alarm occurs, and remains high until the security code + OFF is entered. This is true when a silent panic alarm is initiated via a hardwired or polling loop zone. However, if the duress alarm is initiated via console key depression, the silent panic/duress trigger remains high for about 2 seconds only, then returns to the low state.



**ALARM DEVICE MANUFACTURING CORPORATION**  
A DIVISION OF PITTMAY CORPORATION

**165 Eileen Way, Syosset, New York 11791**

Copyright © 1994 PITTMAY CORPORATION